

A Sample Environment Roadmap for ILL Future

Eddy Lelièvre-Berna

lelievre@ill.eu - <http://www.ill.eu/sane>



SANE
NEUTRON ENVIRONMENT

Send Feedback

Do you have a pioneering idea that could change the way we provide support to our users, or perhaps an innovation that could allow our users to carry out innovative experiments ?



Either way, we value your opinion and want to understand how we can constantly improve. **Leave us your feedback** and be assured that we will carefully review all suggestions.

Feedback...

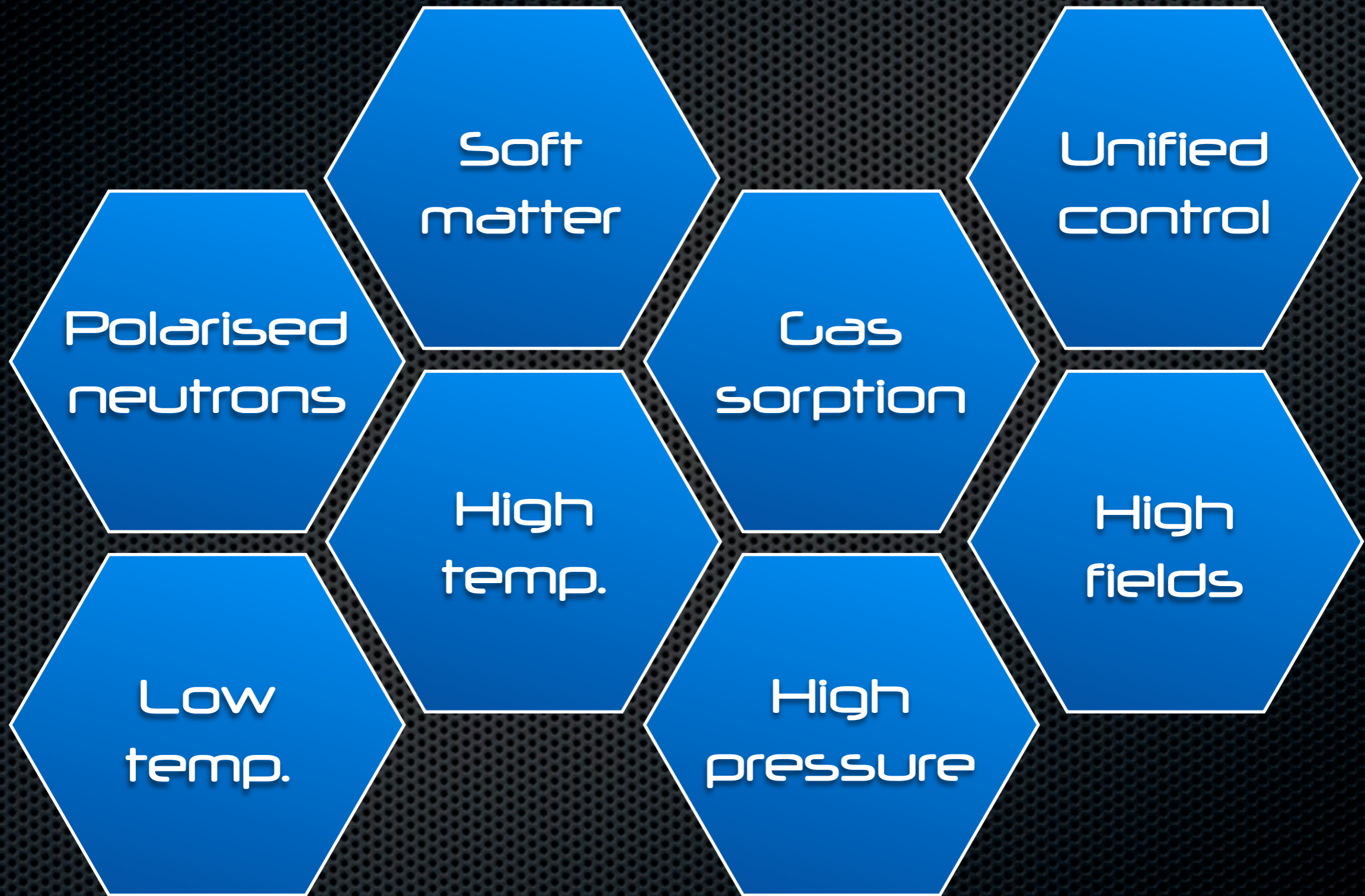

Cryogenics

- **60 cryostats**
1.5 / 2.8 to 320 K
- **16 cryofurnaces**
1.5 to 550 / 650 K



Cryogenics

It is worth recovering helium: +400 k€ saved per year !

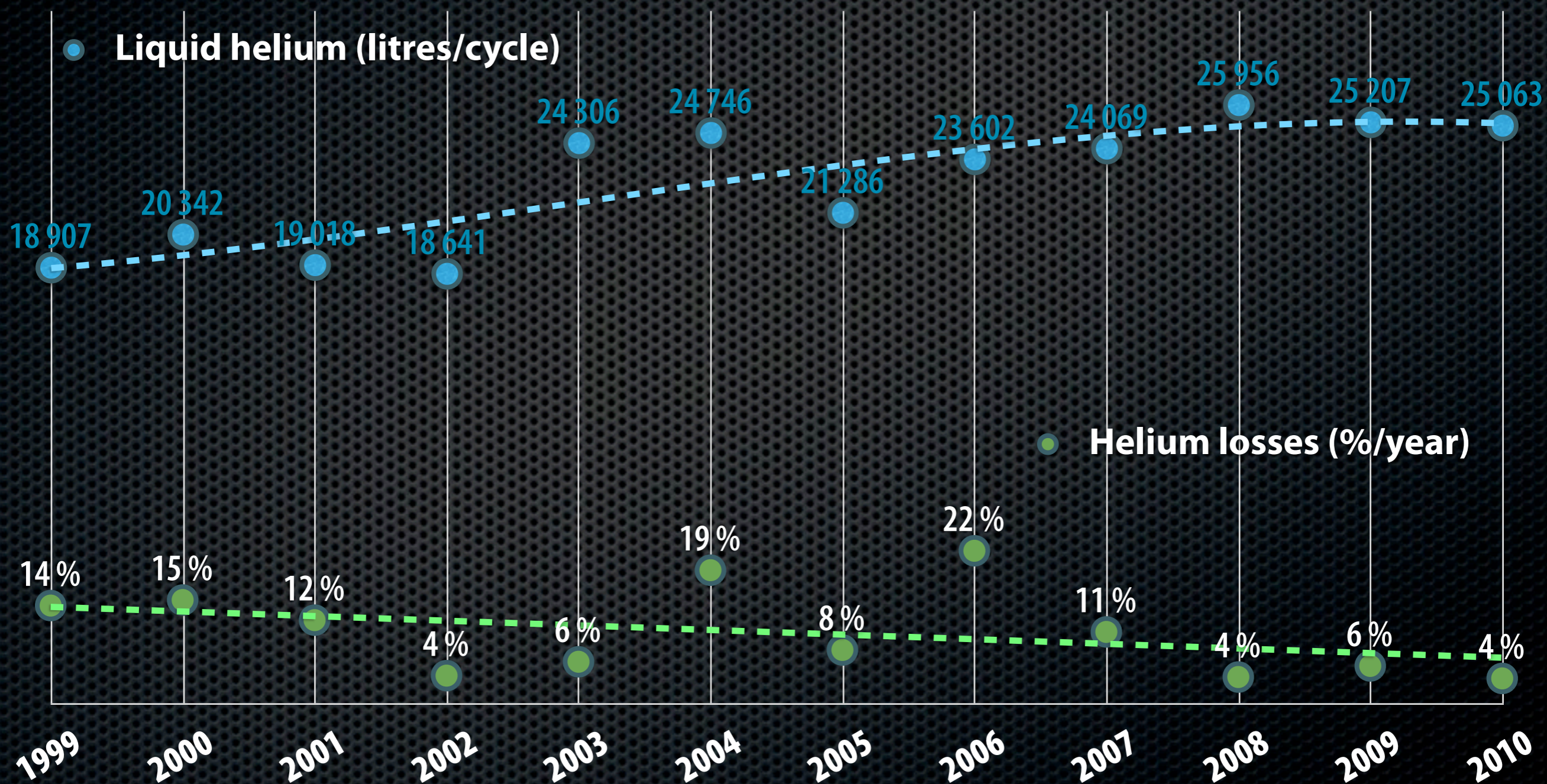

Cryogenics

- ✦ **60 cryostats**
1.5 / 2.8 to 320 K
- ✦ **16 cryofurnaces**
1.5 to 550 / 650 K
- ✦ **New dry cryostats**
D9, D10: 1.8 to 320 K



Cryogenics

- **60 cryostats**
1.5 / 2.8 to 320 K
- **16 cryofurnaces**
1.5 to 550 / 650 K
- **New dry cryostats**
D9, D10: 1.8 to 320 K with JT
IN13: 2.7 to 620 K without JT
soon on Lagrange...

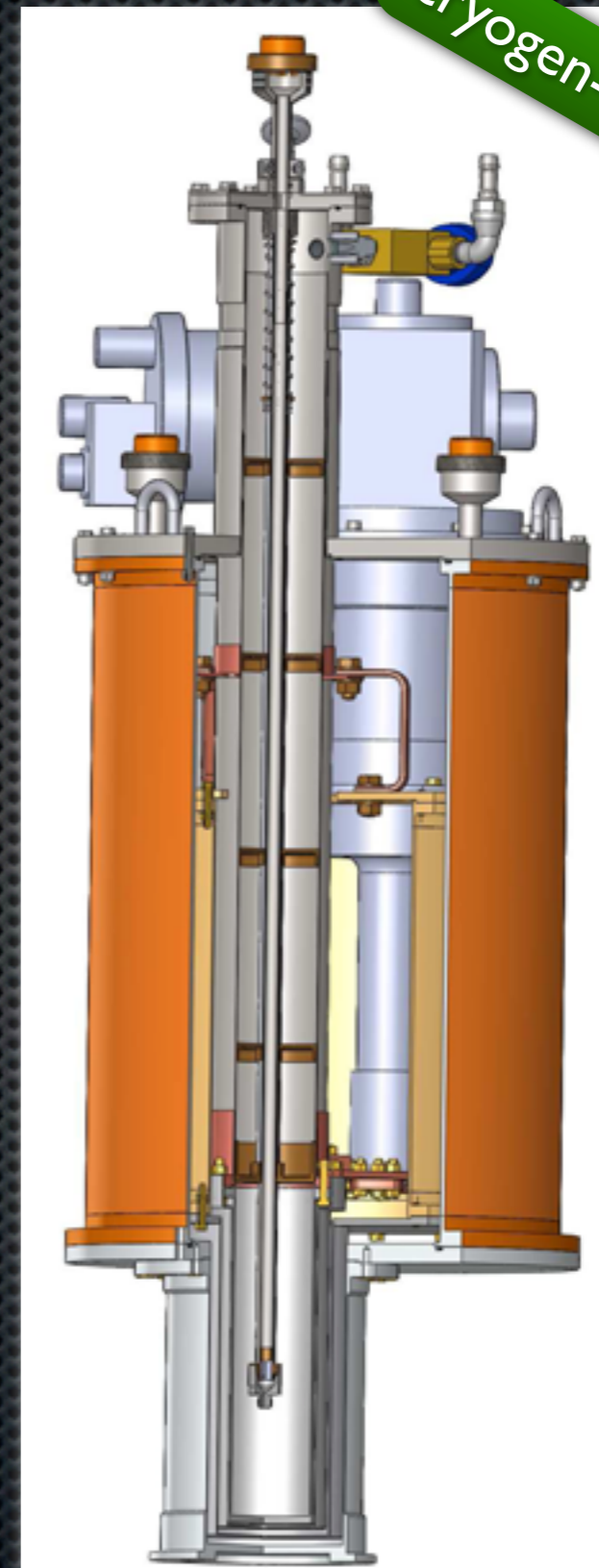

Cryogenics

dry cryostats are easy to use, look fast...

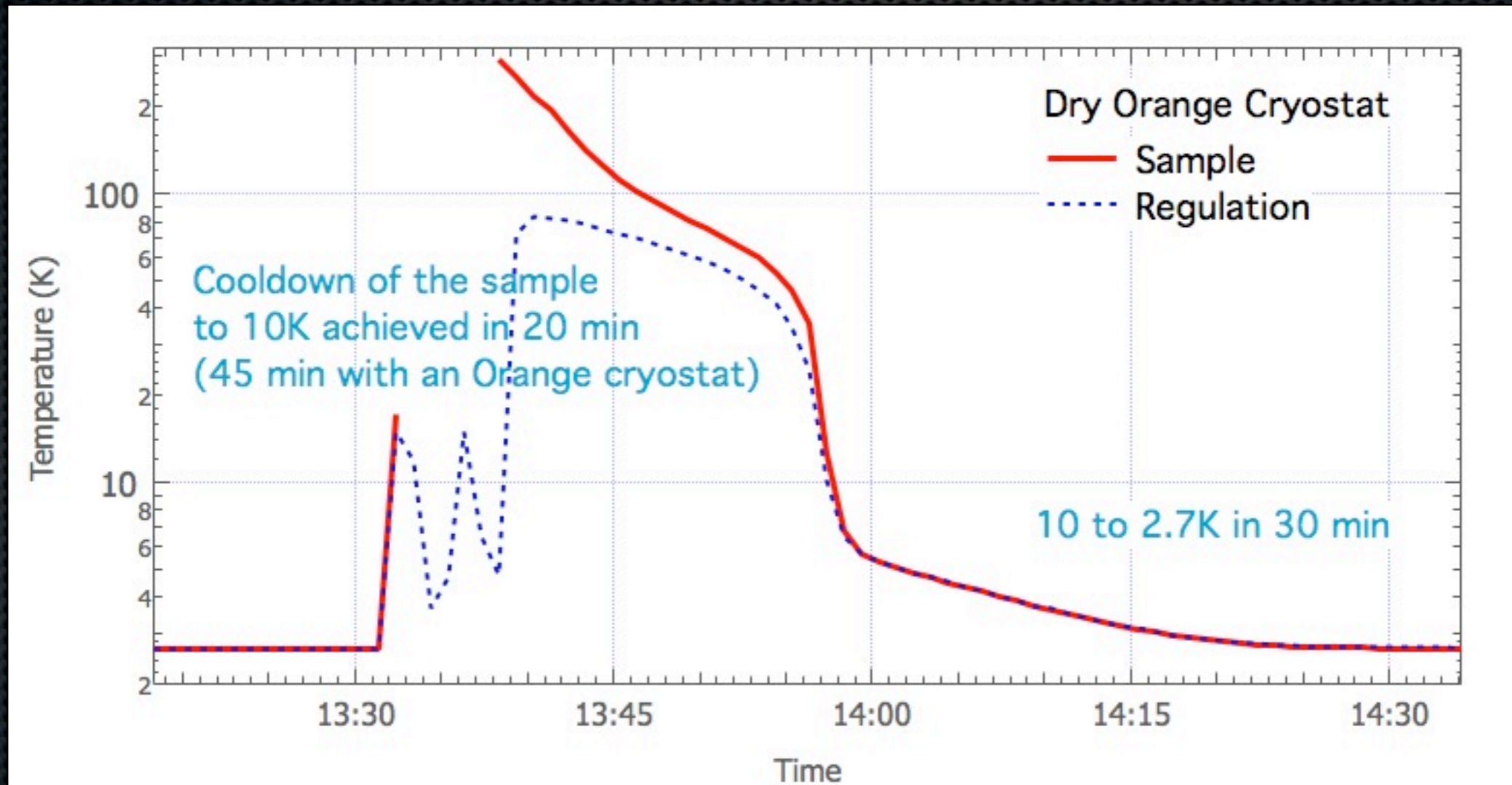

Cryogenics

cryogen-free cryostats are slow !

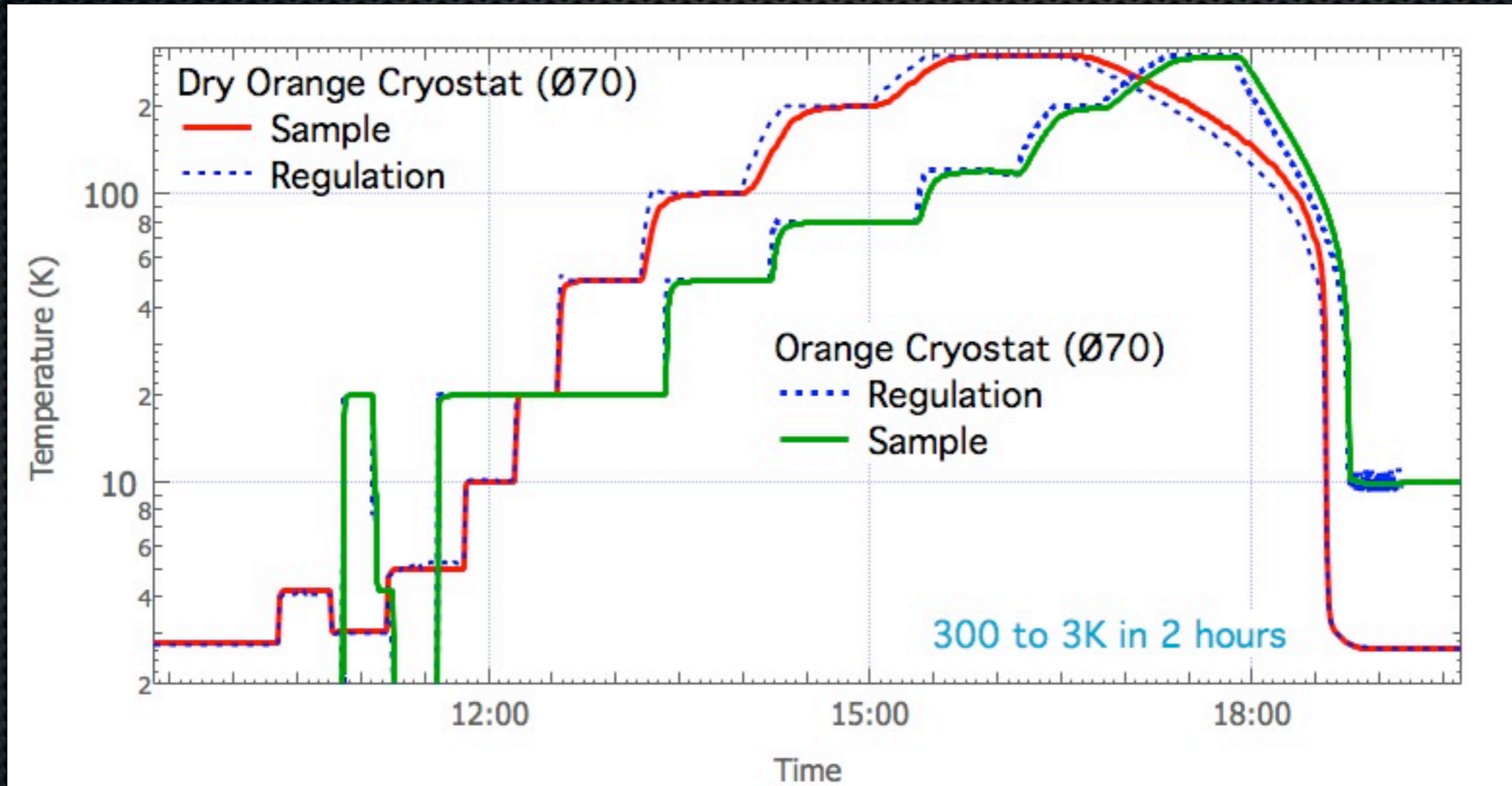

Cryogenics

Much faster cryostats for new-generation instruments ?

x4.5 wet cryostats

x3 with liquid N₂ precool loop fixed to calorimeter

x1.5 with optimized cold-valve control

x3 dry cryostats

x2 with liquid N₂ loop ?

x1.5 with heat switch ?

but still slower by x3...

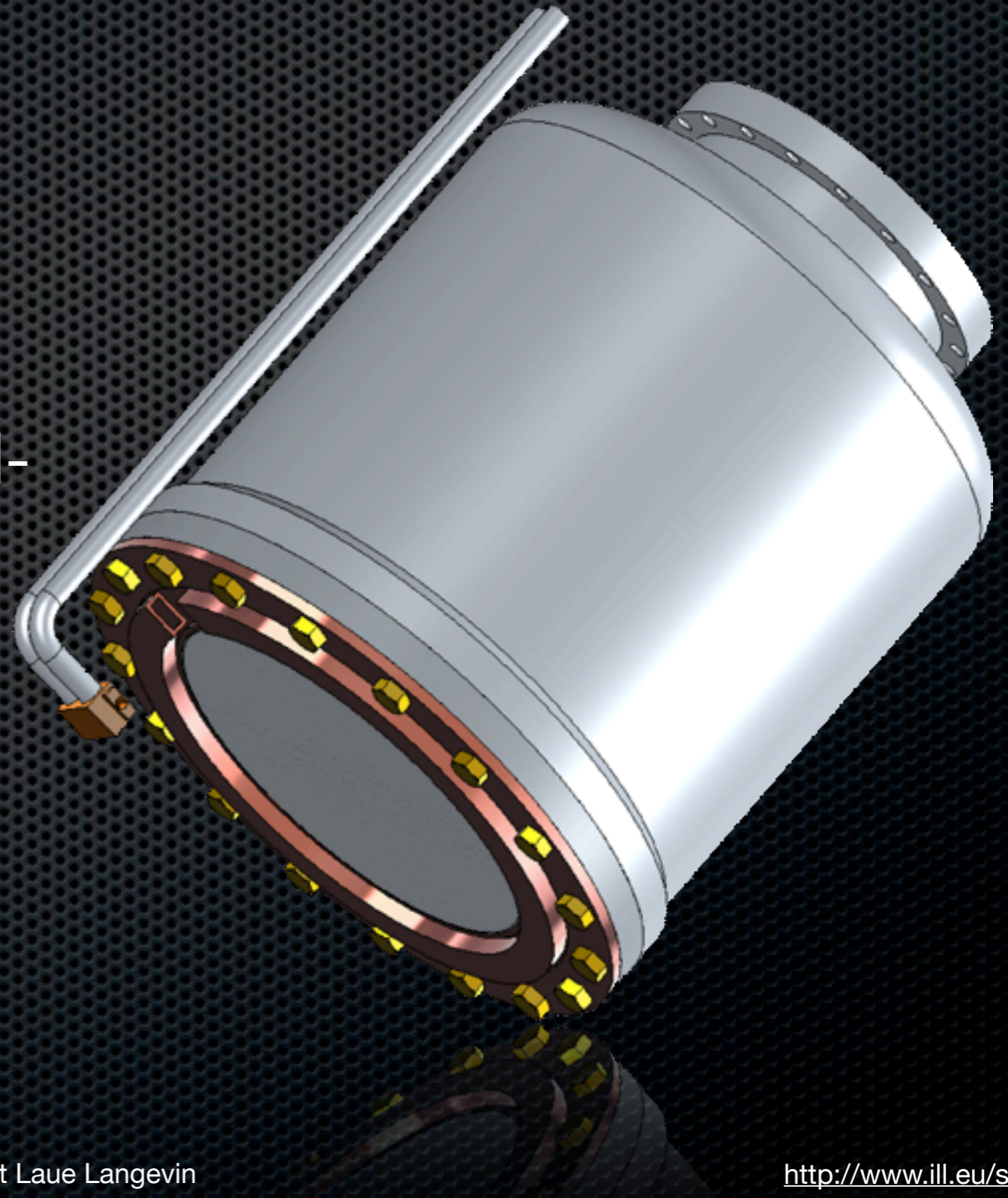

Cryogenics

Sample orientation at a glance

✦ Cold goniometer

$\pm 8^\circ$ sample inclination

± 10 mm along Oz

$\pm 180^\circ$ around Oz

non-magnetic

remotely controlled

for $\varnothing 49$ and $\varnothing 70$ bore

design almost complete...

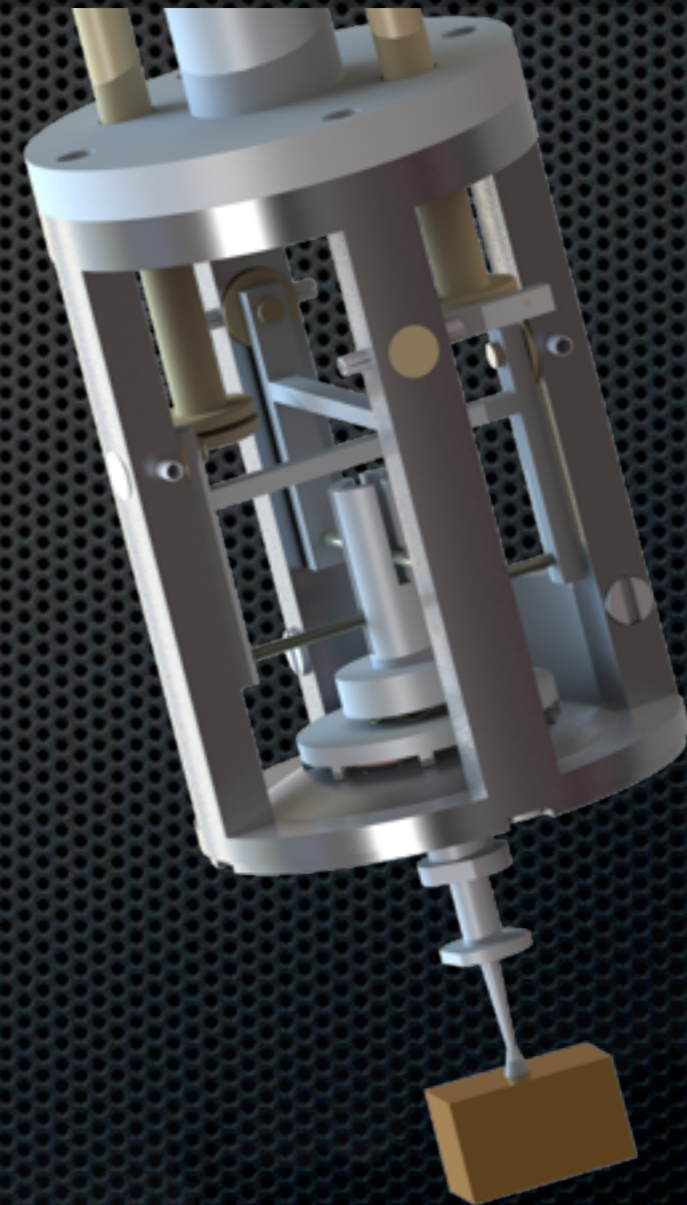

Cryogenics

Sample orientation at a glance

✦ Cold goniometer

$\pm 8^\circ$ sample inclination

± 10 mm along Oz

$\pm 180^\circ$ around Oz

non-magnetic

remotely controlled

for $\varnothing 49$ and $\varnothing 70$ bore

design almost complete...

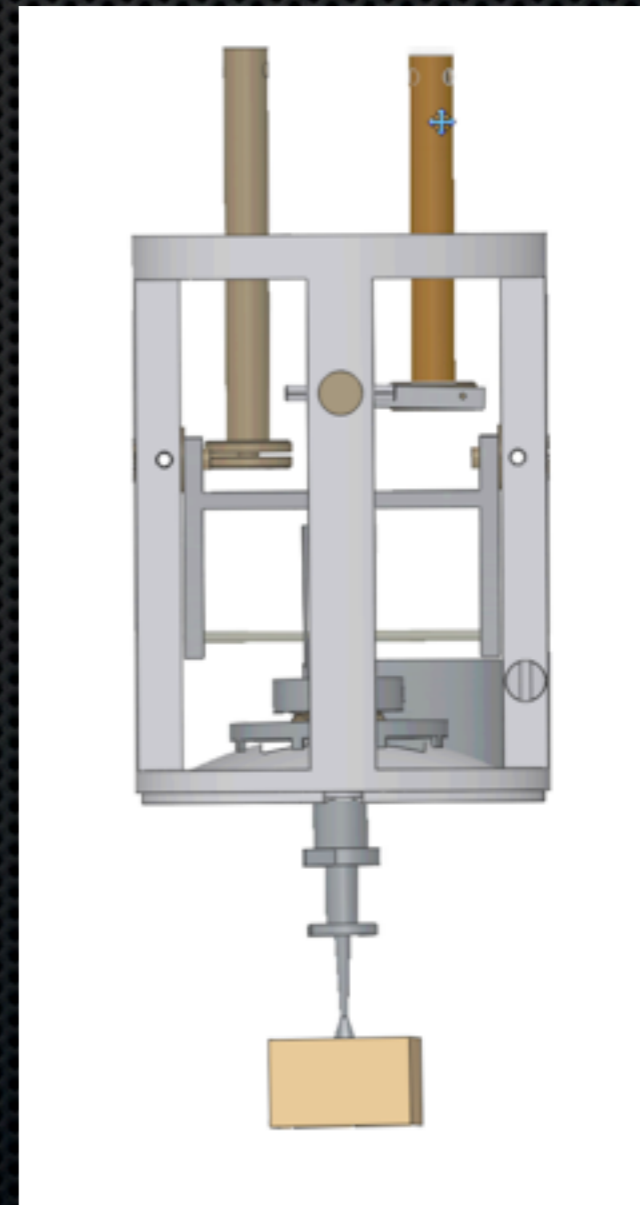

Cryogenics

- ✦ **10 dilution fridges**
15 / 35 mK to 320 K
- ✦ **3 ^3He fridges**
350 mK to 320 K



Cryogenics

- ✦ **10 dilution fridges**
15 / 35 mK to 320 K
- ✦ **3 ^3He fridges**
350 mK to 320 K
- ✦ **D10 dilution fridge**
new ^3He distiller...

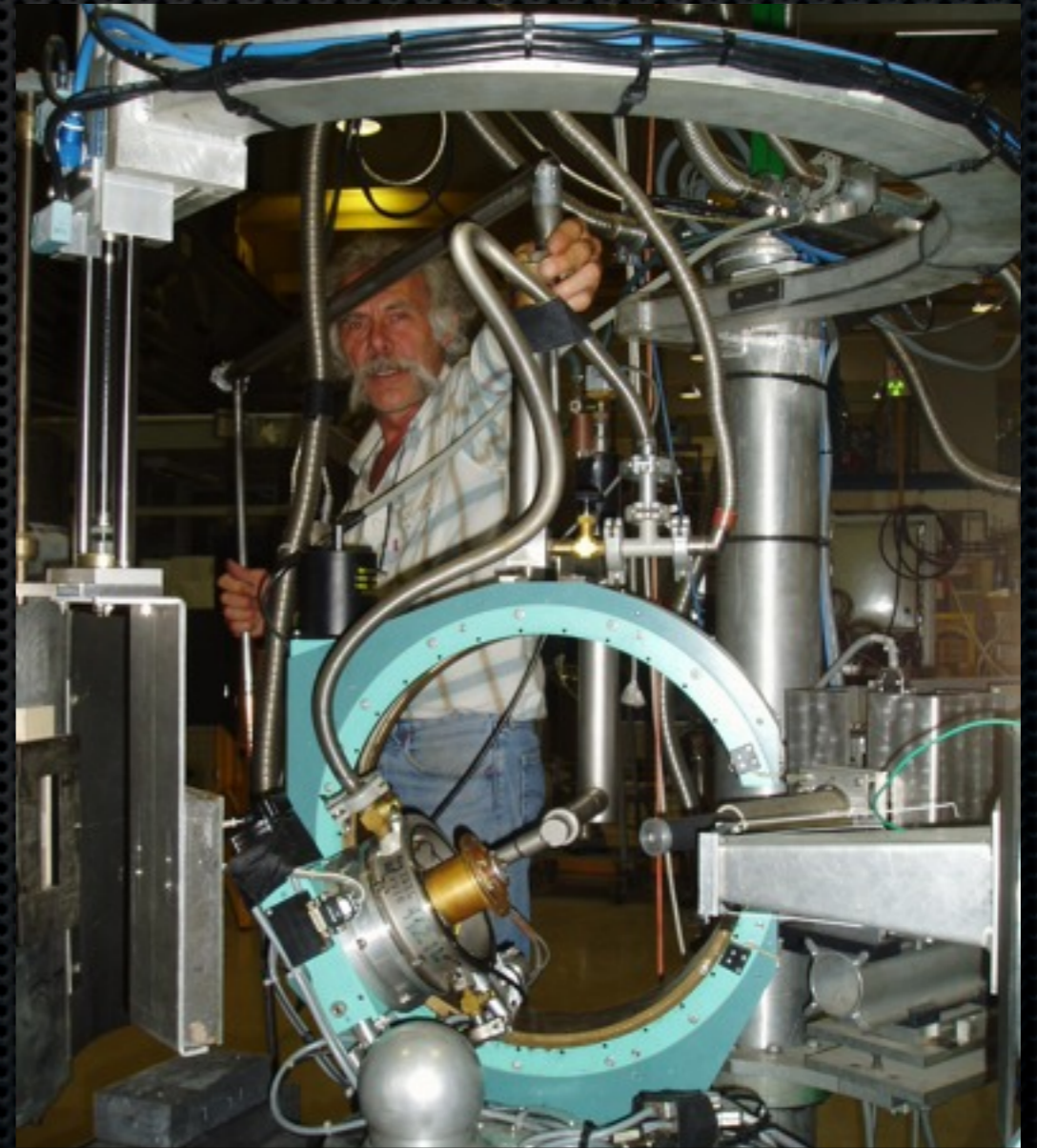

Cryogenics

- ✦ **10 dilution fridges**

15 / 35 mK to 320 K

- ✦ **3 ^3He fridges**

350 mK to 320 K

- ✦ **D10 dilution fridge**

new ^3He distiller...

- ✦ **New dilution fridges**

2 inserts, 1 cryostat soon, new gas handling later...

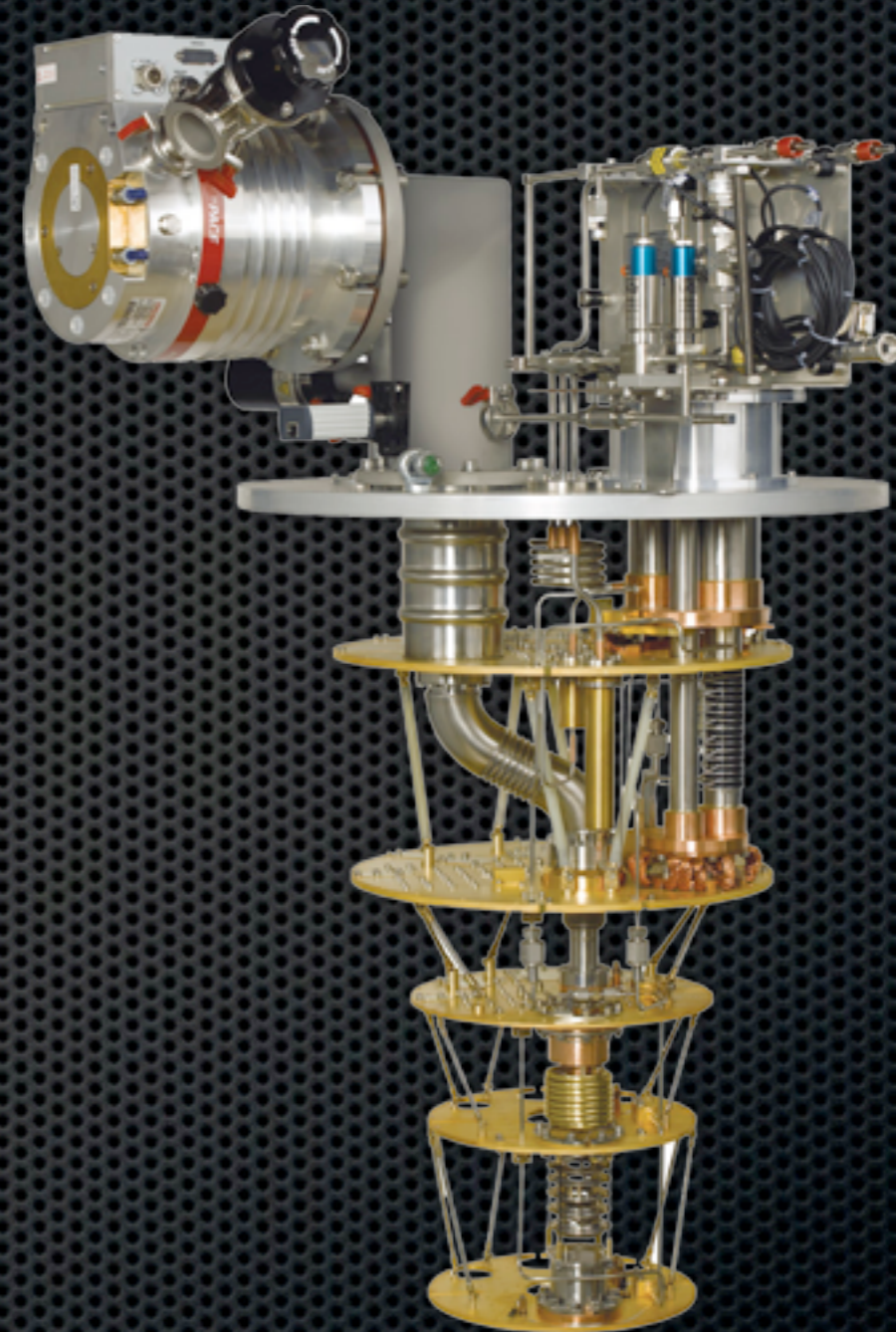

High mag. fields

✦ New cryomagnets

7 T vertical for reflectometry

10 T vertical - ZBO system

17 T horizontal (T. Forgan)

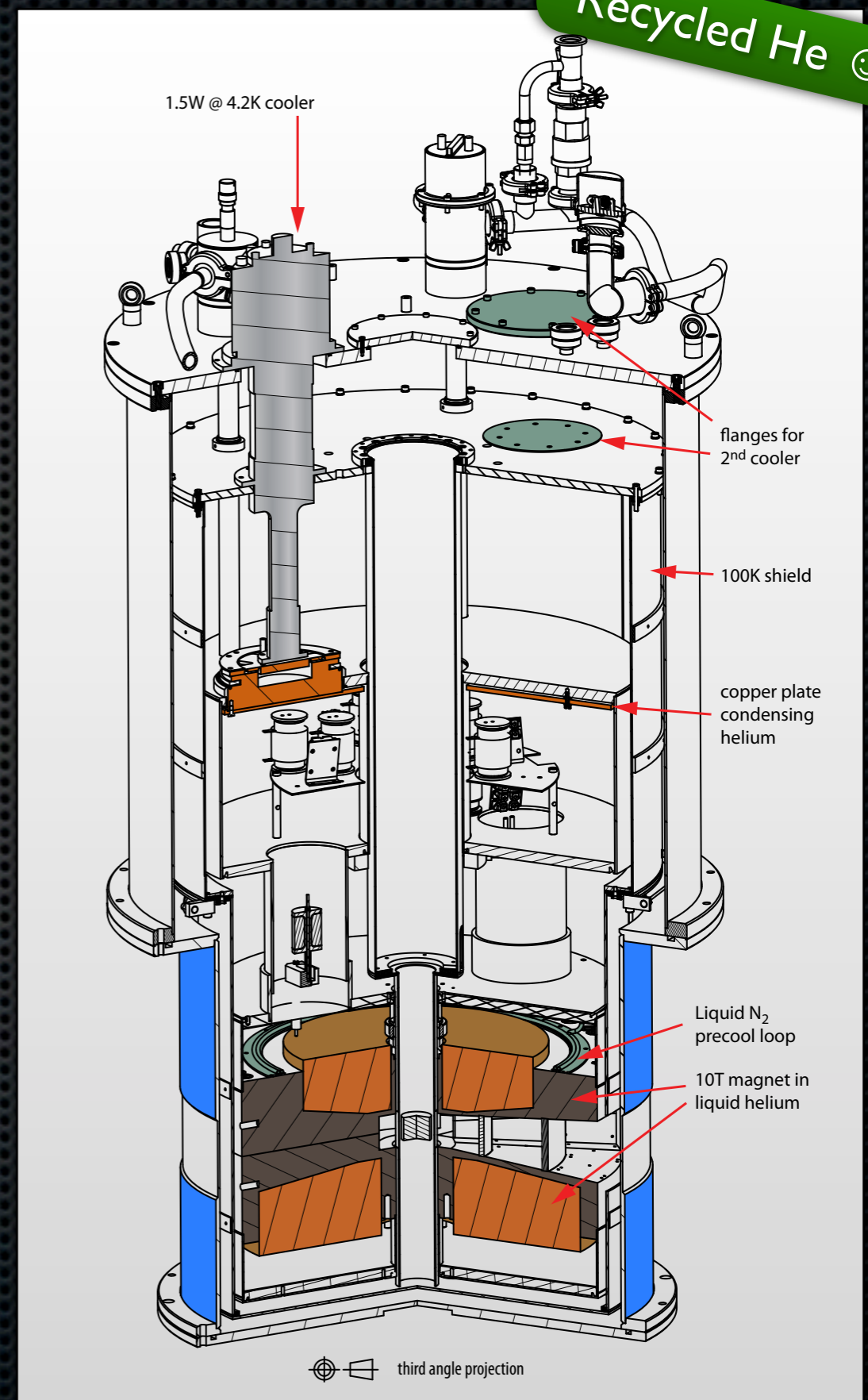

High mag. fields

- ✦ **New cryomagnets**

 - 7 T vertical for reflectometry

 - 10 T vertical - ZBO system

 - 17 T horizontal (T. Forgan)

- ✦ **+2 T with Dy booster**

 - Simulations complete,

 - Dy rod delivered,

 - Drawings in progress...

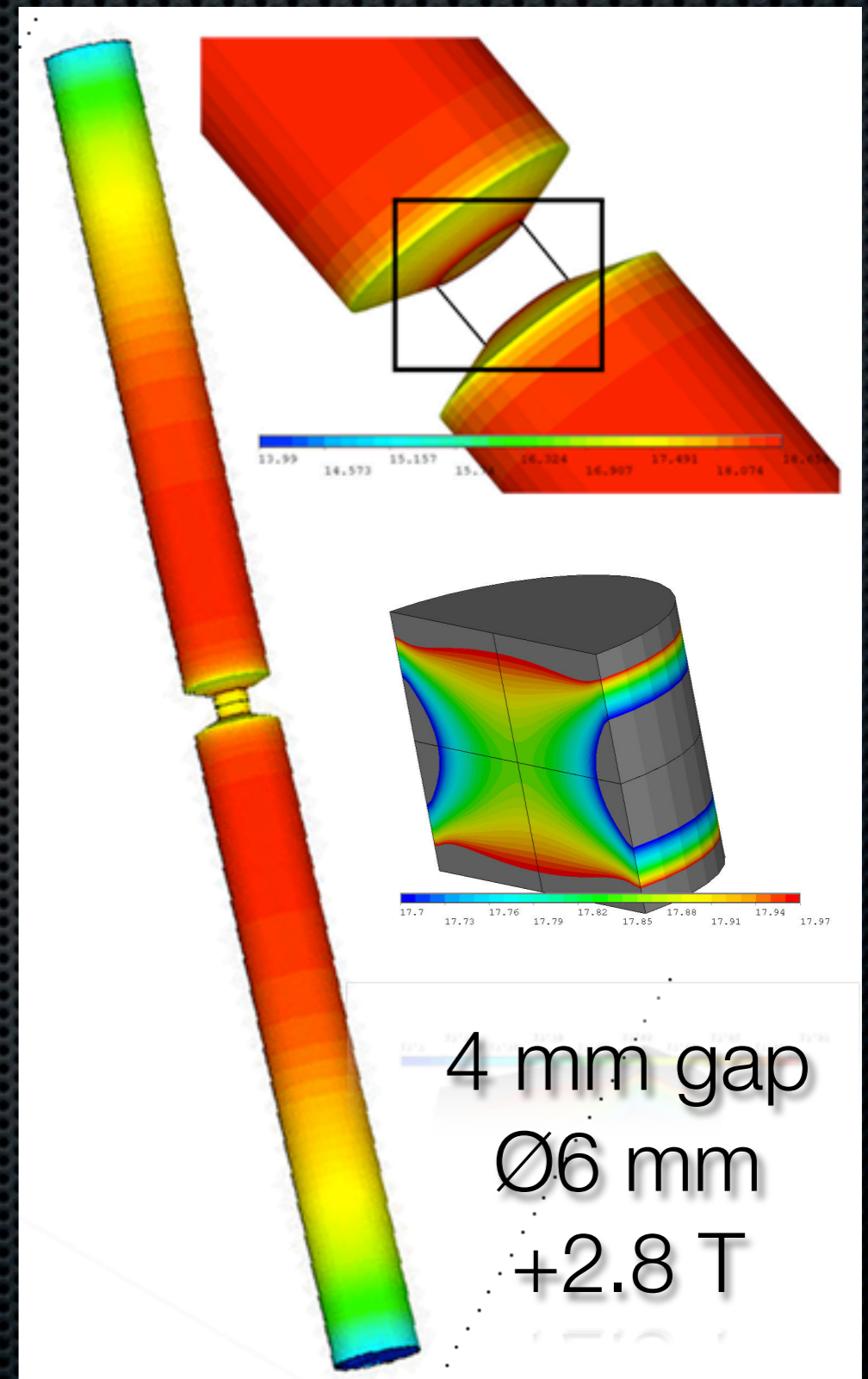

High mag. fields

- ✦ **New cryomagnets**
 - 7 T vertical for reflectometry
 - 10 T vertical - ZBO system
 - 17 T horizontal (T. Forgan)
- ✦ **+2 T with Dy booster**
 - Drawings in progress...
- ✦ **40 T pulsed field magnet**
 - In design phase...

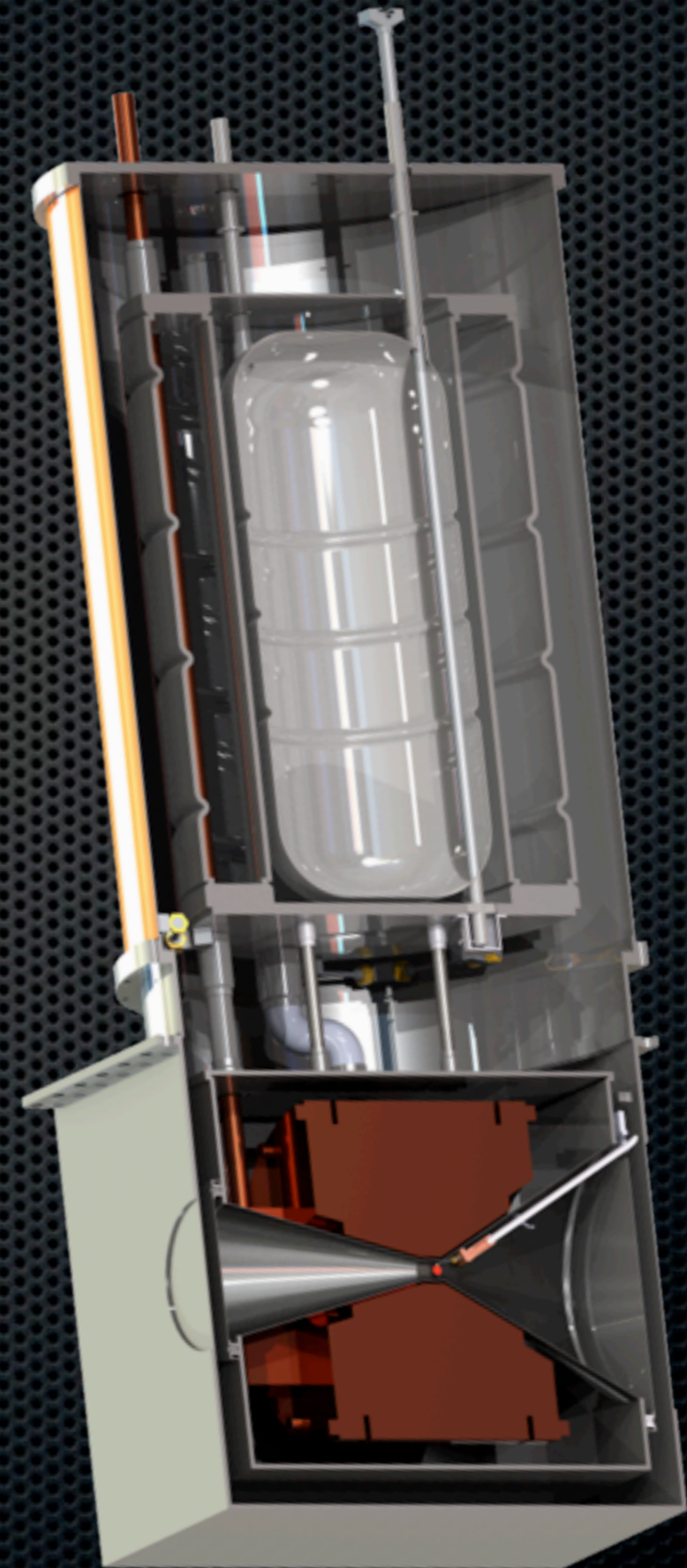

High temperature

- **23 furnaces**

320 to 1900K

V, Nb resistors

Sapphire windows

mirror furnace



High temperature

- ✦ **23 furnaces**
 - 320 to 1900K
- ✦ **7 new auto-power racks**
 - 2 kVA and 3.5 kVA
 - Fully automatic
 - Much safer
 - Ethernet I/O



High temperature

- ✦ **23 furnaces**
- ✦ **7 new auto-power racks**
Fully automatic, available
- ✦ **New furnace for cradles**
300 to 1100 K in 1h30
30' to cool down to 650 K
30' to replace the heater
being commissioned...



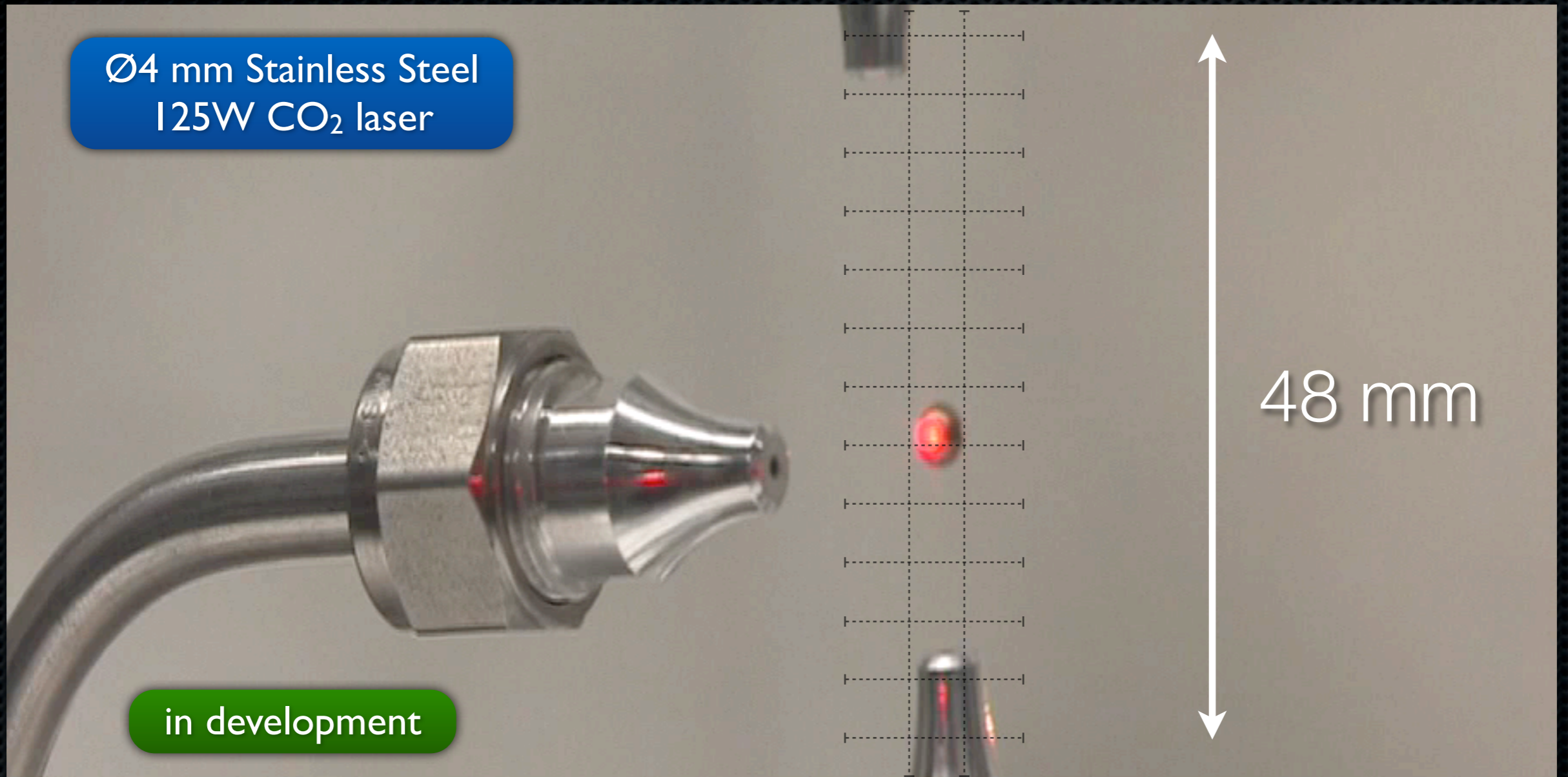

Aerodynamic levitation

Collaboration with CEMHTI, SIMAP and Soleil

High pressure

- ✦ **6 clamps (fluorinert)**
 - 1 to 3 GPa (4 GPa ?)
- ✦ **9 presses (inert gas)**
 - 0.5 to 10 GPa (20 GPa)
 - at 120 K in 3h from 300 K
 - another 3 hours to 3 K
 - 2 automatic controllers (He)
- ✦ **New non-magnetic VX-1**

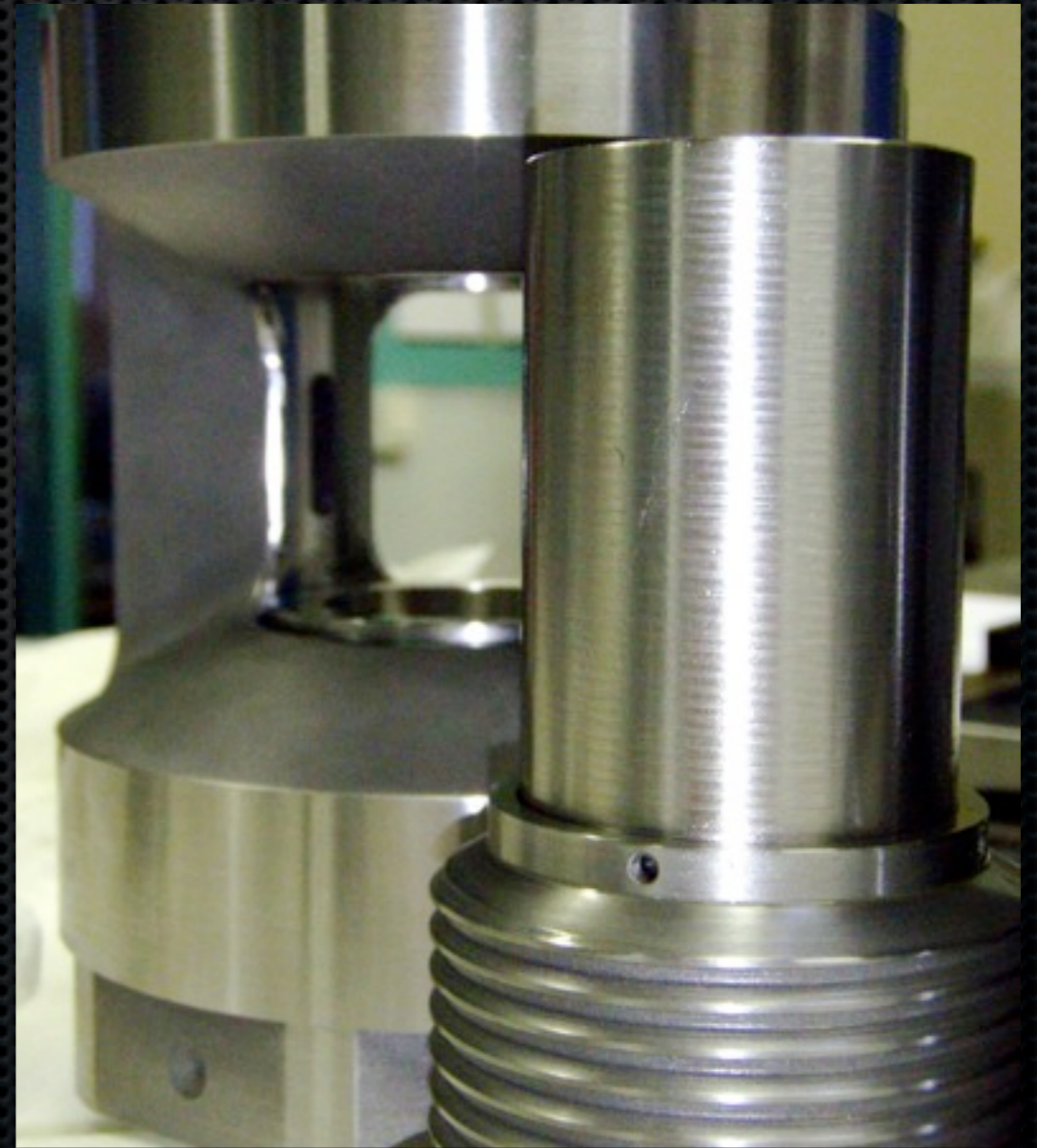

High pressure

- **6 clamps (fluorinert)**
1 to 3 GPa (4 GPa ?)
- **9 presses (inert gas)**
0.5 to 10 GPa (20 GPa)
at 120 K in 3h from 300 K
another 3 hours to 3 K
2 automatic controllers (He)
- **New non-magnetic VX-1**



High pressure

- **6 clamps (fluorinert)**
 - 1 to 3 GPa (4 GPa ?)
- **9 presses (inert gas)**
 - 0.5 to 10 GPa (20 GPa)
 - at 120 K in 3h from 300 K
 - another 3 hours to 3 K
 - 2 automatic controllers (He)
- **New non-magnetic VX-1**



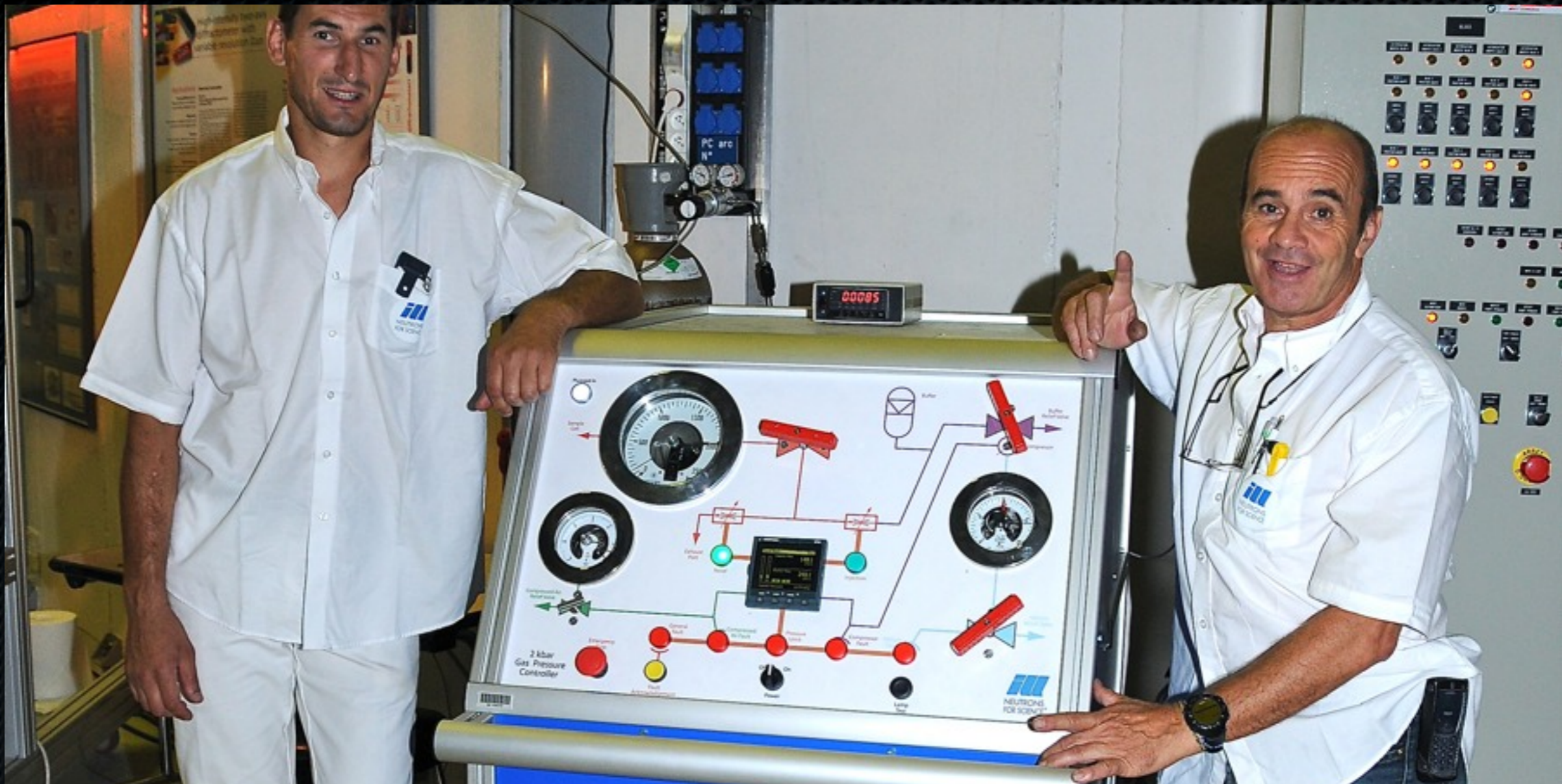

Automatic controller

up to 20 GPa in 20 min - 10^{-4} stability



Gas Sorption

200 bar automated volumetric sorption analysers



Gas Sorption

80 and 700 bar gas injection sticks for cryostats

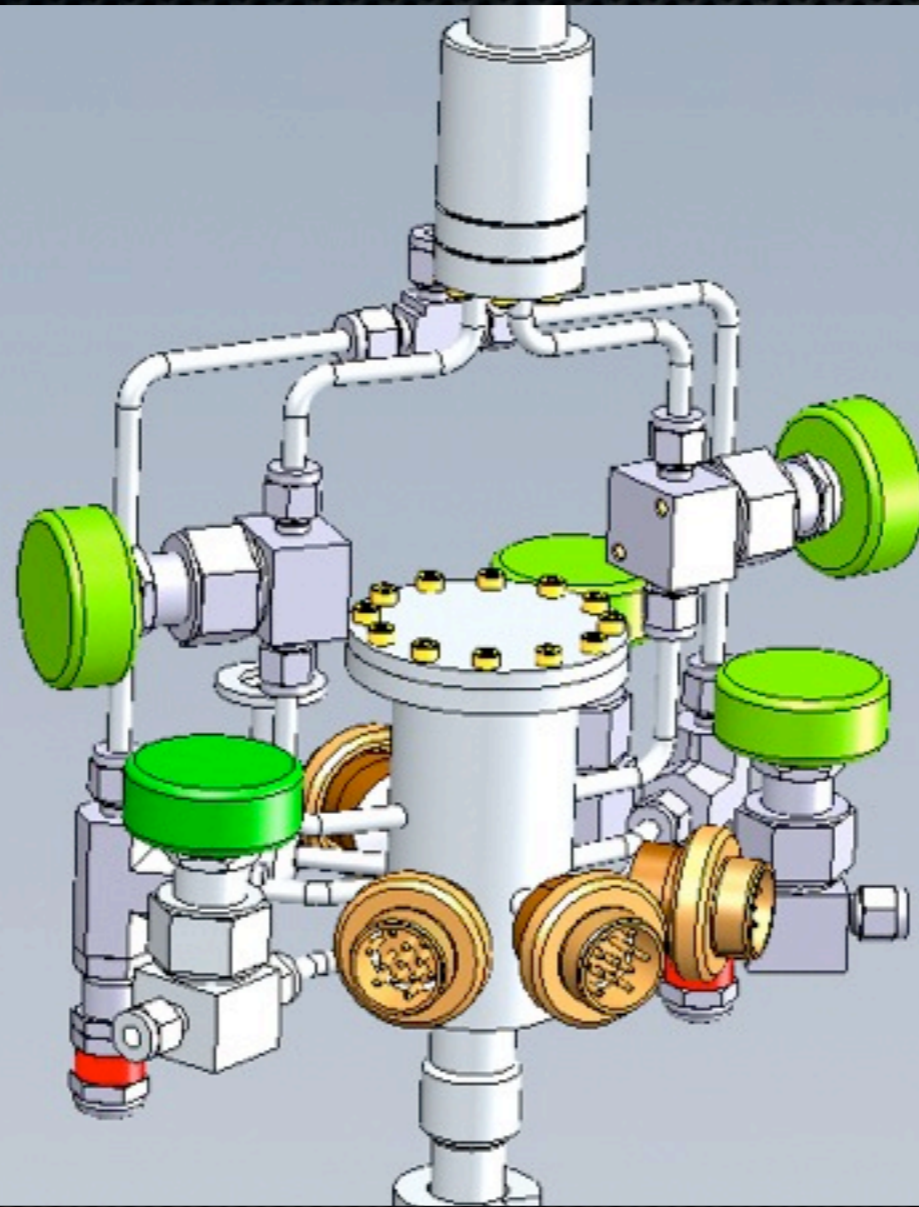

Gas Sorption

ANSTO - HZB - ILL shared design (being built)

Polarimetry

- ✦ **Cryopad, today...**

D3, IN14, IN15, IN20,
IN22, PF1B @ ILL

TAS-1 @ JAEA

Poli-HeiDi @ FRM II



Polarimetry

- ✦ **Cryopad, today...**

D3, IN14, IN15, IN20,
IN22, PF1B @ ILL

TAS-1 @ JAEA

Poli-HeiDi @ FRM II

- ✦ **Cryopad-EDM**

Being designed in
collaboration with PNPI
Goal: 10^{-26} e.cm...!



Polarimetry

- **Cryopad-EDM**

Being designed in collaboration with PNPI...
Goal: 10^{-26} e.cm...!

- **Cryopad with wide-angle analysis, ToF option**

The design is being evaluated with R. Pynn et al. (NSF grant)

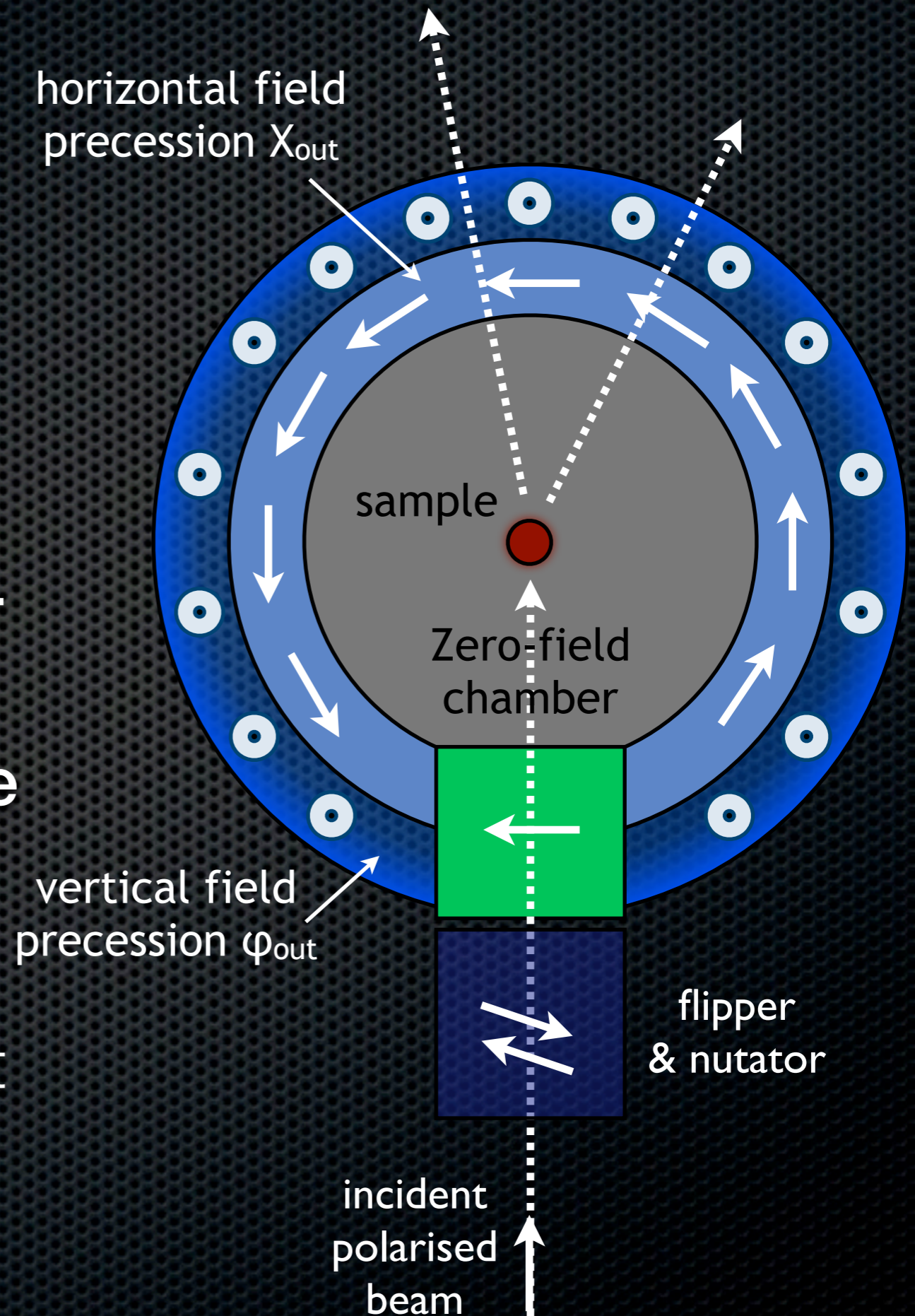

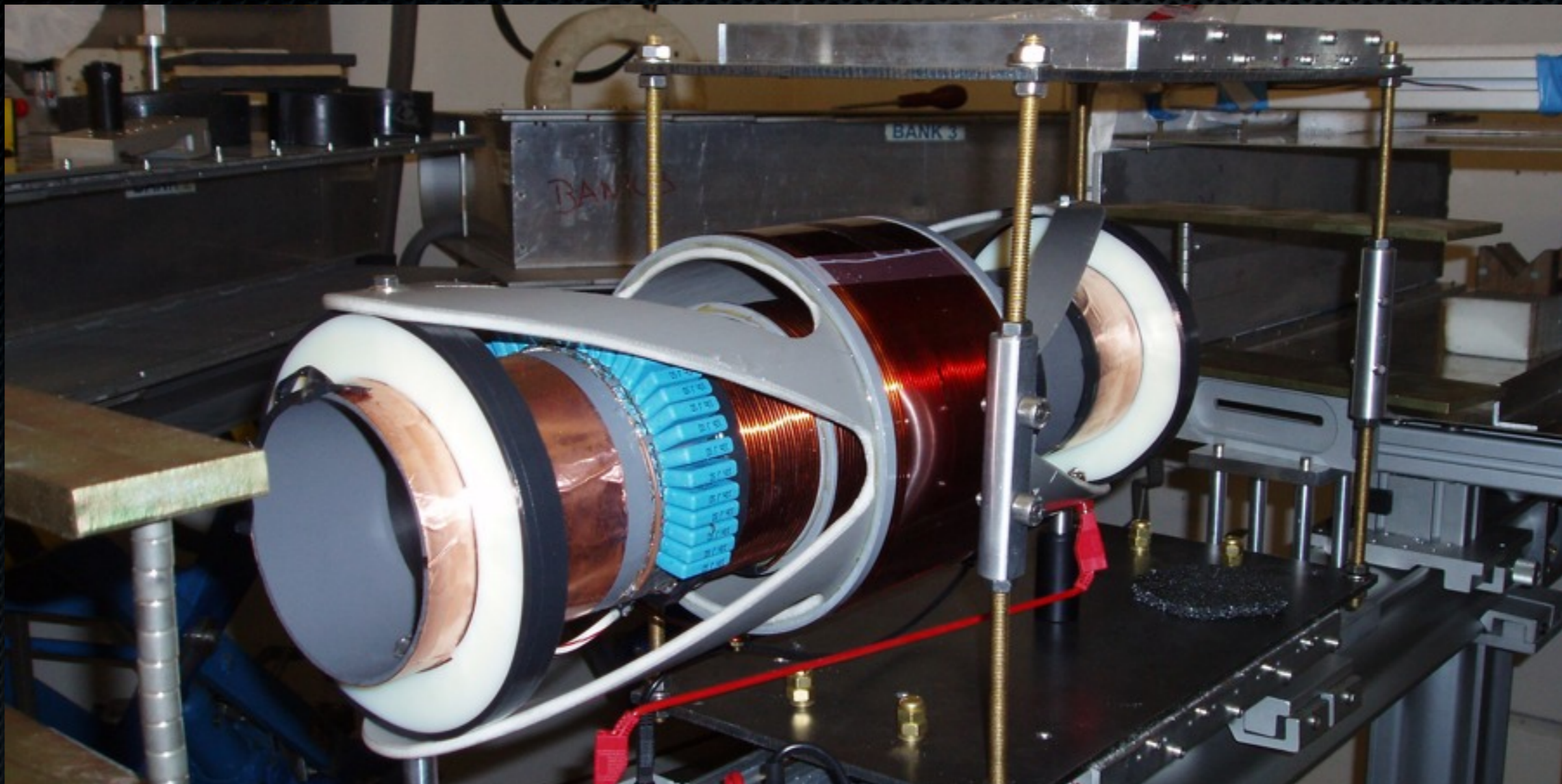

20-200kHz adiabatic flippers

Auto-tune power supply in construction (800 W)

Neutron spin filters



99.9% efficient
flipper above
 0.3 \AA in
400 Gauss
stray field

$T_1 \approx 120$ hours
at 1 bar

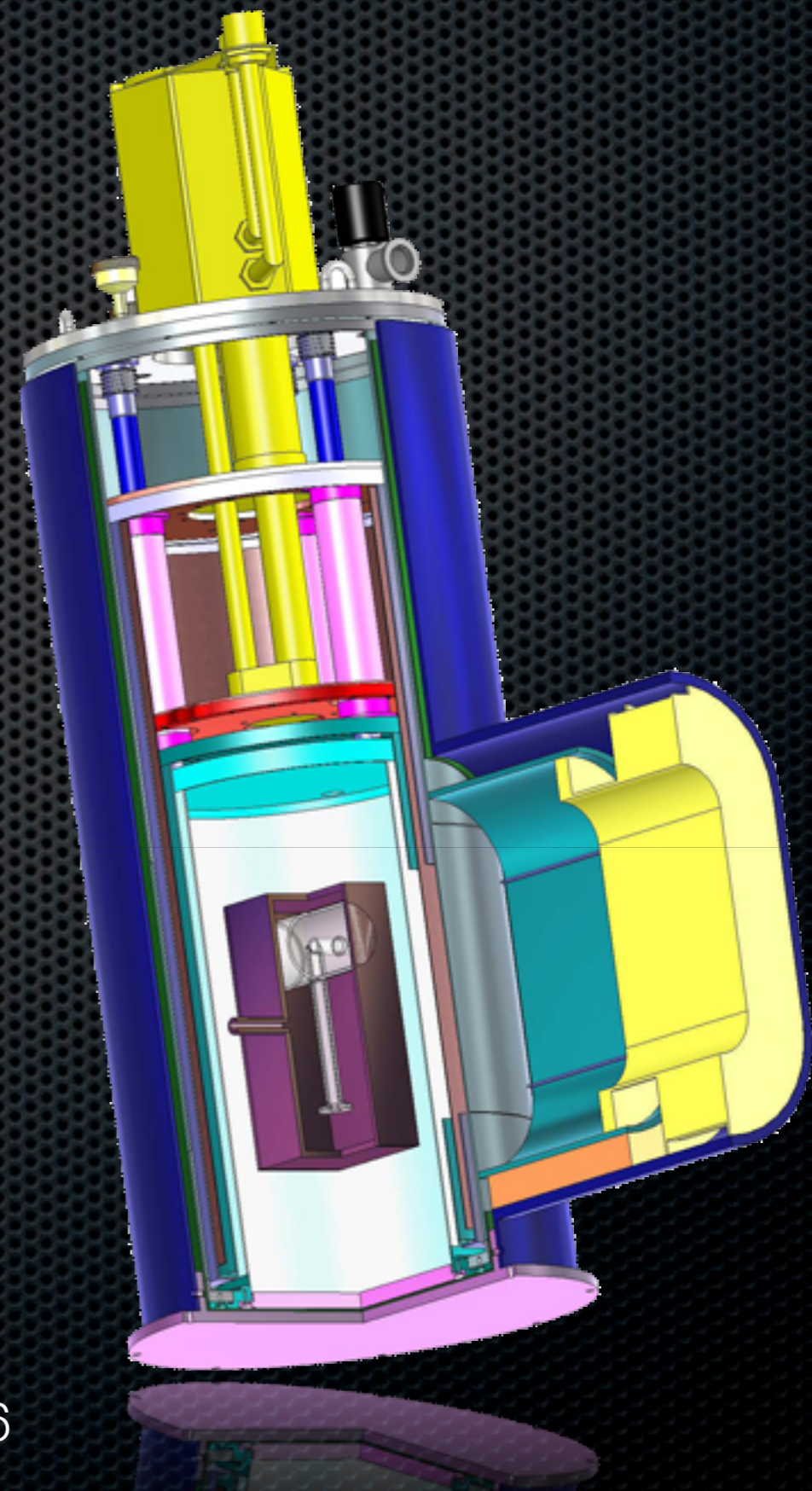

Meas. Sci. Technol. 21 (2010) 055106

Neutron spin filters

SEOP on-line pumping system in construction for PF1B

in construction

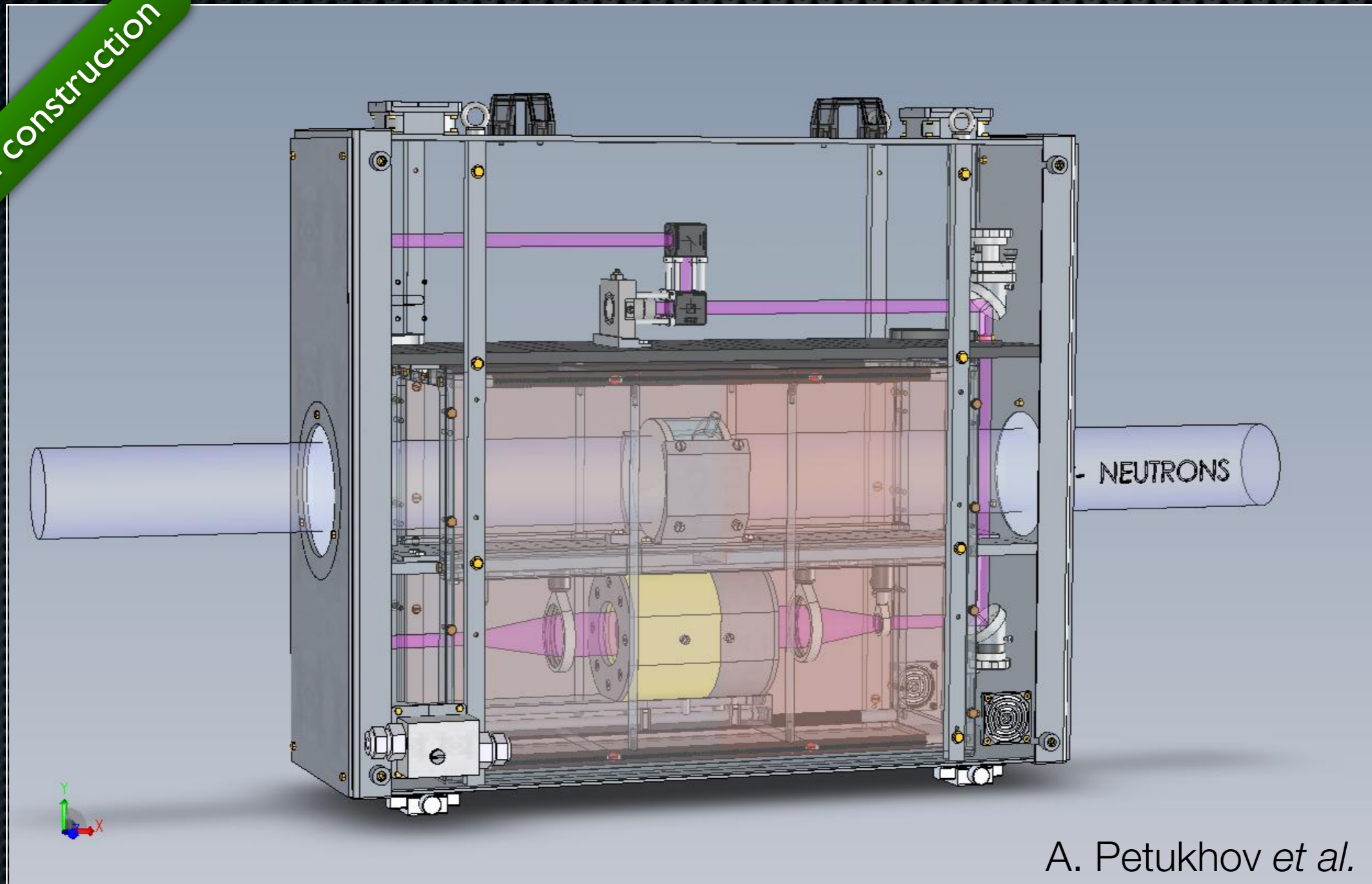

A. Petukhov *et al.*

SANE - Services for Advanced Neutron Environment

Highly qualified staff to carry out invaluable experiments...

We provide experienced technical support, and premium hardware.



NEUTRONS[®]
FOR SCIENCE

Institut Laue-Langevin

www > Instruments & Support > Sample Environment > About Us

SE@NSF 2010

The 6th international workshop on Sample Environment at Neutron Scattering Facilities took place in Herrsching at Lake Ammersee near Munich (Sept. 30 - Oct. 1). It was greatly organized by our colleagues from FRM II during October fest. [Learn more...](#)

ANR Magfins

The kick-off meeting of the Magfins project financed by the **Agence Nationale de la Recherche** will soon be held at ILL. This project aims at building a pulsed field magnet.



Sample Env. JRA

Together with our colleagues from FRM II, HZB, ISIS and LLB, we are developing new gas handlings and pressure cells for inert gas and hydrogen, containerless furnaces and gas sorption systems. This Joint Research Activity is supported by the **European Commission** through the **NMI3** project.



ANR Strudvie

Temperature Controllers Settings



The PID parameters to be used with our **cryostats**, **cryofurnaces** and **cryomagnets** have been tuned for **LakeShore** controllers with **Kepeco** power amplifiers. The calibration curves of the Cernox thermometers are available from the **Equipment** section. [Learn more...](#)

0.2GPa Helium Gas Controller

In order to improve the control of the **continuously loaded pressure cells**, we have constructed a rack using the high-precision 0.2GPa valve patented by the CNRS. Best efforts have been performed for speeding up the controller while maintaining a high stability at any pressure.

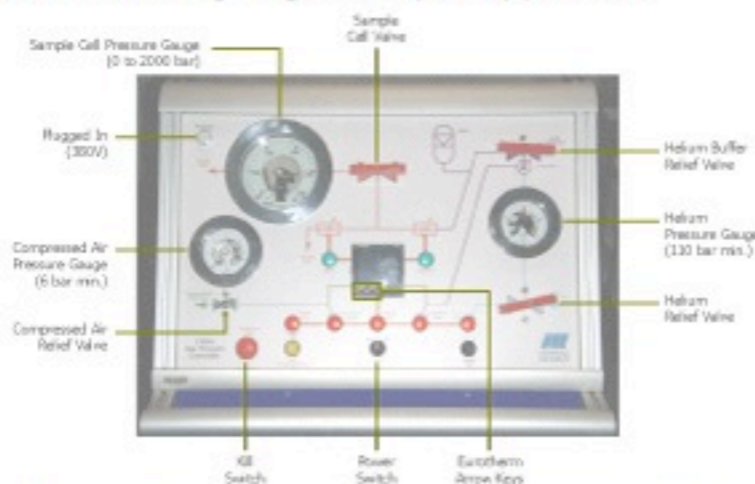

This controller has recently been commissioned with the 4 and 10 GPa Paris-Edinburgh presses. [Learn more...](#)

Furnaces Controlled Automatically

7 fully automated power-crates have been designed and built for controlling our resistive furnaces. Switch-on,

New 4GPa Pressure Presses

We have recently acquired two new VX-1 Paris-Edinburgh cells. One will be controlled with helium gas and the other with oil. With these new cells, we will better cover the 1-4 GPa pressure range.

It is planned to build a cryogen-free cryostat as we did for the 10GPa press so that measurement can be carried out down to 3K. For the time being, the cryostat of the 10GPa press is shared with the 4GPa.



New 10T Cryomagnet



A new vertical field 10T asymmetric split-pair coil cryomagnet will be available on the three-axis spectrometers and some of the diffractometers in 2011.

There is no liquid nitrogen required and a recondensing system reduces the liquid helium boil-off. The variable temperature insert being installed and a dilution insert is in construction.

The maximum sample volume will be $\varnothing 39 \times 30$ mm.

New 7T Cryomagnet

A 7T vertical field asymmetric magnet also featuring a recondensation unit has been recently delivered. The variable temperature insert is under construction and the single-crystalline sapphire are ordered. This cryomagnet is designed for reflectometers and SANS instruments and should be available this summer.

Helium Pumping Crates

Support

Out of hours support is provided in cryogenics during operating cycles. Local-contacts, please call **66850** to reach our experts. [Learn more...](#)



In trouble with an Orange cryostat? Have a look at our [Trouble Shooting Guide...](#)

Order Liquid Helium

Please, **order your helium** at least 48 hours in advance so that we can satisfy your needs.

Book Equipments

The use of our equipments is scheduled in shared calendars. You can check your bookings and look for the availabilities before scheduling an experiment. [Check calendars...](#)

Safety and Magnets

Please be careful at the proximity of cryomagnets! The mechanical limits must always be installed and checked before starting an experiment. [Learn more...](#)



Send Feedback

LN2 Level Monitors

[Instruction Manual](#)[Technical Specs](#)

LHe Level Monitors

Cold-Valve Controllers

Temperature Controller

Instruction Manual

The ILL liquid nitrogen level monitor has been carefully designed and manufactured to provide hours of trouble free service. Its user interface has also been designed so as to simplify as much as possible its operation. The monitor also has several features that are not available on other commercial systems: a large display for easy reading on large instruments and a full remote access allowing users to monitor different cryostats without the need for recalibrating.

The level monitor uses a capacitive sensor connected to an oscillator. The oscillator is powered by the monitor with a 10V DC signal and read with the +/- 10V DC voltmeter integrated into the level monitor. The monitor also provides a 24V DC signal to control the cryogenic solenoid valve mounted on the liquid nitrogen dewar. It is delivered fully tested and ready to be calibrated. We describe below how to install, operate and remotely control the level monitor.



Installation & Calibration



press "STOP" to stop a fill

For calibrating our liquid nitrogen level monitor, please click on these five interactive steps

- Switch on the nitrogen level monitor and wait for its initialisation.
- The nitrogen level is measured and displayed permanently with a bar graph and large digits.
- A manual fill is launched by pressing the "REFILL" button.
- During a fill, press the "STOP" button to abort it.

- 1 Switch ON
- 2 Enter calibration mode
- 3 Set low level
- 4 Set high level
- 5 Exit calibration mode

Operation

The monitor manages the readings and the fills. The user can easily set the low and high levels, the alarm level and the fill timeout. The refills are started when the low level is reached or when the user presses the command "REFILL". The fill cycle will end when the level reaches the high limit, when the fill timeout expires, or when the user presses the "STOP" command. When the fill timeout expires, the refill is aborted and the alarm remains active until the user acknowledges it.

LN2 Level Monitors

LHe Level Monitors

Cold-Valve Controllers

Temperature Controller

[Instruction Manual](#)

Instruction Manual

When installing a cryostat, cryofurnace or cryomagnet, the settings of the LakeShore 340 temperature controller must be verified and changed following the procedures detailed below. When complete, do not forget to switch on the heater by pressing the **Heater Range** key.

Calibration curves

Thermometers are installed on the heat exchanger of the variable temperature inserts and at the bottom of the sample sticks. Sometimes, there are also a few other thermometers for specific purposes. Generally, we use Cernox CX1050 sensors in cryostats and RhFe sensors in cryofurnaces. The thermometers are referenced with a serial number which is determined by visiting the Equipment section above: by clicking on the cryostat code name, you get the serial number of the thermometers. You can even download the calibration curves compatible with the LakeShore 340.

By convention, the Cernox or Rhodium Iron sensor of the heat exchanger (regulation) is plugged to the Channel A of the LakeShore. The thermometer of the sample is plugged to the Channel C. In most cases, there are also Pt100 sensors attached to our equipments. They can be read with the Channels B and D respectively but they are used as spare thermometers; when the Cernox or Rhodium Iron sensors cannot be read correctly.

1. On the LakeShore, press the **Input Setup** key to display the **INPUT SETUP** screen.
2. Use the **Up** or **Down** key to select Channel A.
3. Press the **Next Setting** key until the **Type** field is highlighted. Use the **Up** or **Down** key to select the sensor you wish, e.g. Cernox, Rhodium Iron, etc.
4. Press the **Previous Setting** key to highlight the **Curve** field. Use the **Up** or **Down** key to select the calibration curve you wish.
5. Press the **Previous Setting** key to highlight the **Therm Comp** field. Use the **Up** or **Down** key to select **ON** for a Cernox and **OFF** for a Pt100 or a RhFe.
6. Press the **Previous Setting** key to highlight the **Enable** field. Use the **Up** or **Down** key to select **ON**.
7. Press the **Previous Setting** key to highlight the **Input** field. Repeat the sequence with channel B, C and D from step #3.
8. Press the **Save Screen** key to save the settings.
9. Press again the **Save Screen** key to return to the main panel.

```

Input: A      INPUT SETUP
             Enable: ON      Type: Rhodium Iron
             Therm Comp: OFF
                                 Sensor Unit: Ω
                                 Temp Coeff: Pos.
Curve: 23 RHFE      Excitation: 1mA
SN: D077           Range: 250Ω
  
```

Input Setup screen of the LakeShore 340 for a cryofurnace.



LakeShore 340 Manual



Kepco ATE Specifications

» **To top**

Zone control data entry

The LakeShore 340 allows the user to establish up to 10 custom temperature zones where the controller automatically uses pre-programmed **PID settings and heater range**. These values have been determined at the cryogeny lab. for families of cryostats and must be entered in the controller after installing a new type of cryostat. We describe below the procedure to follow for entering these settings:

1. On the LakeShore, press the **Zone Settings** key to display the **ZONE SETTINGS** screen.
2. Use the **Up** or **Down** key to select Loop 1.
3. Press the **Next Setting** key to highlight the **Top** value of the first row.
4. Use the numerical keypad and the **Enter** key to enter new zone values. Parameters that can be specified are **Top** of the zone (in K), proportional (**P**), integral (**I**), derivative (**D**), Manual Output in percent (**MOut%**), and Heater Range. Enter these parameters for each zone.
5. When complete, press the **Save Screen** key to save the settings.
6. Press again the **Save Screen** key to return to the main panel.
7. Once the zones are programmed, you must place the controller in zone mode. This is described below, together with other parameters.

```

Loop: 1      ZONE SETTINGS
             Top    P      I      D      MOut% Range
1  100  0.0  0.0  0  0.00 OFF
2  100  0.0  0.0  0  0.00 OFF
3  100  0.0  0.0  0  0.00 OFF
4  100  0.0  0.0  0  0.00 OFF
5  100  0.0  0.0  0  0.00 OFF
  
```

Zone Settings screen of the LakeShore 340 before entering the values.

» **To top**

Control setup

These settings normally needs to be entered only once. They do not depend on the equipment unless for very particular reasons.

1. On the LakeShore, press the **Control Setup** key to display the **CONTROL SETUP** screen.
2. Use the **Up** or **Down** key to select Loop 1.
3. Press the **Next Setting** key to highlight the **Enable** field. Select **ON** with the **Up** and

```

Loop: 1      CONTROL SETUP      <more>
  
```

SANE - Services for Advanced Neutron Environment

Highly qualified staff to carry out invaluable experiments...

We provide experienced technical support, and premium hardware.



NEUTRONS[®]
FOR SCIENCE

Institut Laue-Langevin

[www](#) > [Instruments & Support](#) > [Sample Environment](#) > [Equipment](#) > [Calendars & Wikis](#)

[Calendars & Wikis](#)

Calendars of the Equipments

Click on an icon and enter the login "ill" and password "ill" to access the calendars.
NB: The calendars of the equipments are only accessible from the Intranet.



Cryostats



Cryofurnaces



3He Refrigerators



Dilution Refrigerators



Gas Sorption



Hor. Magnets



Vert. Magnets



Polarimetry



Furnaces (pool)



Furnaces (inst.)



Clamped Cells



Cont. Loaded Cells



Others



Tags [+](#)

> Edited Dec 4, 2010 1:37 PM by Eddy Lellèvre-Berna...

★ Dilution Refrigerators



In brief...

- The [calendars](#) of the cryostats have moved. The navigation has been improved and that should be easier to book an equipment. If you wish to subscribe to the calendars with any CalDAV compatible software, please [contact us](#).
- The wiki pages are accessible to everyone. Do not hesitate to comment and let feedback.
- You can subscribe to the RSS feeds for getting the news automatically.

For booking a cryostat, click [Book equipment](#).

For updating or letting a comment in the logbook of a dilution refrigerator, click on the identification code below:

- Cryostats: [95ILDIL80](#), [121ILDIL20](#), [144ILDIL80](#)
- Inserts: [162ILDIL20](#), [165ILDIL32](#), [178ILDIL36](#), [179ILDIL36](#), [194ILDIL33](#), [195ILDIL33](#), [196ILDIL33](#)

For visiting the SANE web pages, click [Visit Us](#).

Out-of-hour support: call 66850 from the instrument.

What's Hot

- > [Bookings...](#)
December 4, 2010 1:29 PM

Recent Changes

- > [Dilution Refrigerators](#)
December 4, 2010 1:37 PM
- > [Dilution Insert 196ILDIL33](#)
December 4, 2010 1:37 PM
- > [Dilution Insert 195ILDIL33](#)
December 4, 2010 1:37 PM
- > [Dilution Insert 194ILDIL33](#)
December 4, 2010 1:36 PM
- > [Dilution Insert 179ILDIL36](#)
December 4, 2010 1:35 PM

Upcoming Events

- > No upcoming events.

today

day week month

settings

- 100mK 121DIL...
- 15mK 144ILDIL80
- 15mK 95ILDIL80
- 30mK 162ILDIL20
- 40mK 165ILDIL32
- 40mK 178ILDIL36
- 40mK 179ILDIL36
- 50mK 194ILDIL33
- 50mK 195ILDIL33
- 50mK 196ILDIL33
- 50mK CRG CEA

July, 2011

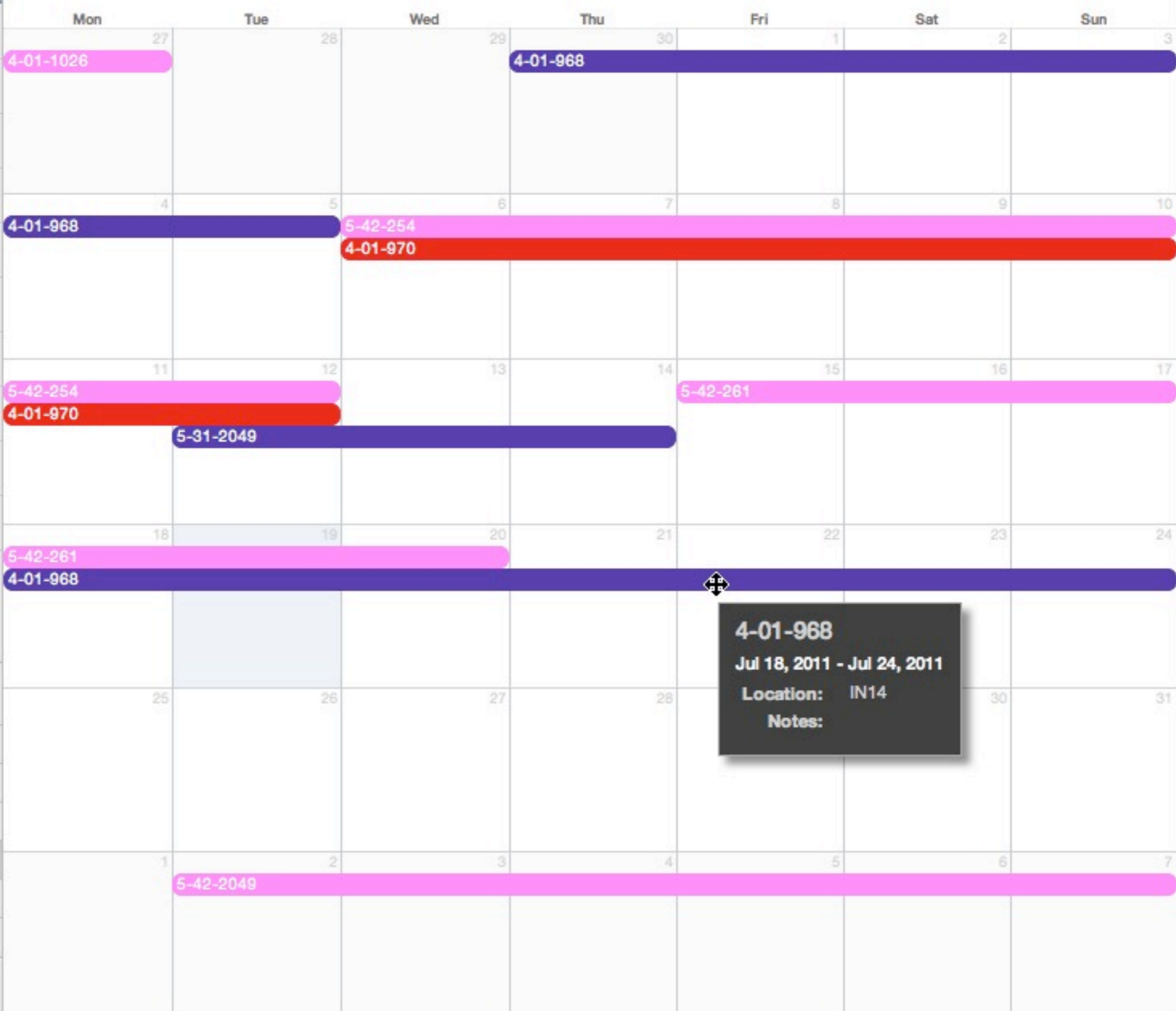

4-01-968
 Jul 18, 2011 - Jul 24, 2011
 Location: IN14
 Notes:



+ [calendar icon]

Unified & dynamic control

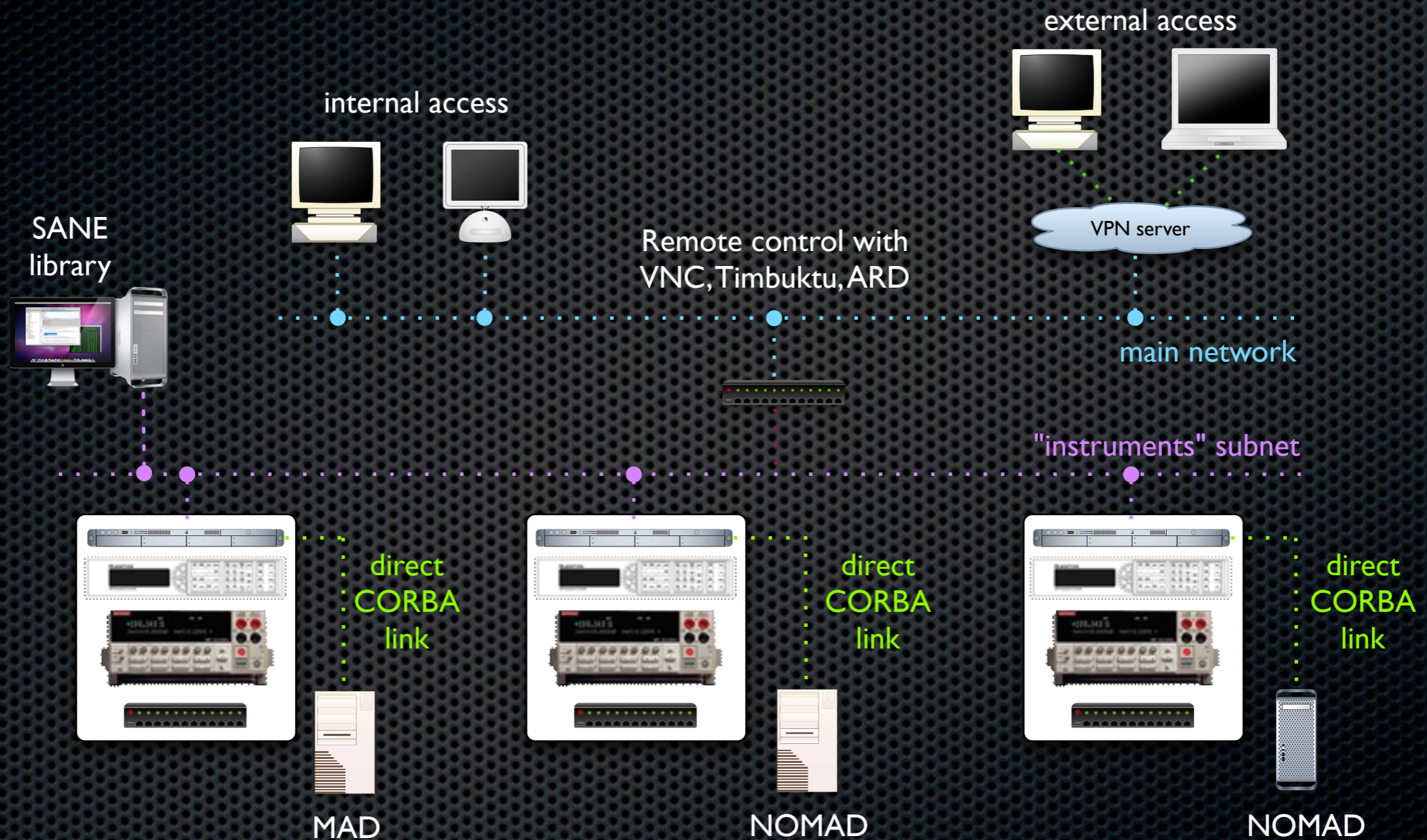

for cryostats, furnaces, pressure systems, humidity chambers, etc...

Unified & dynamic control

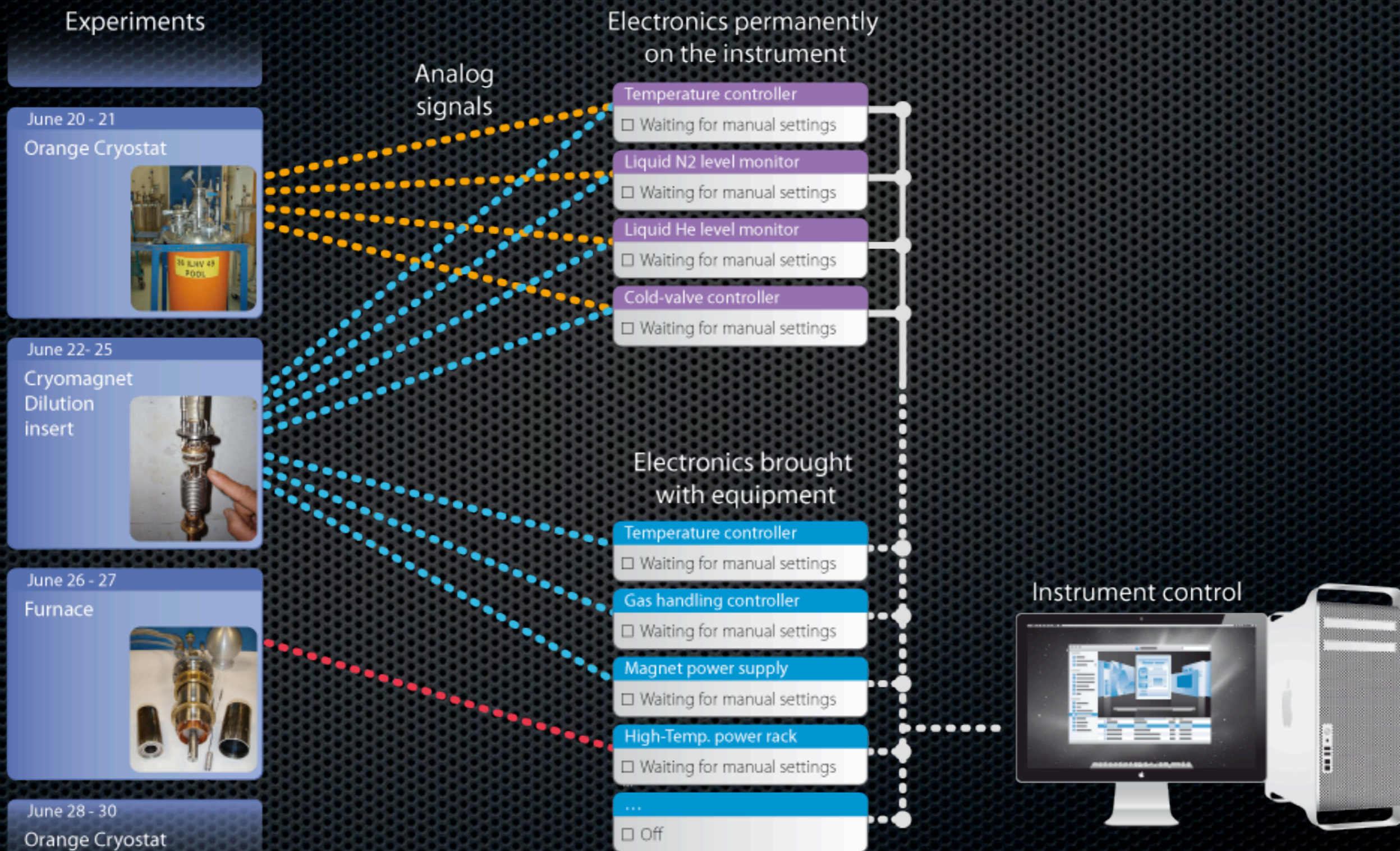

Unified & dynamic control

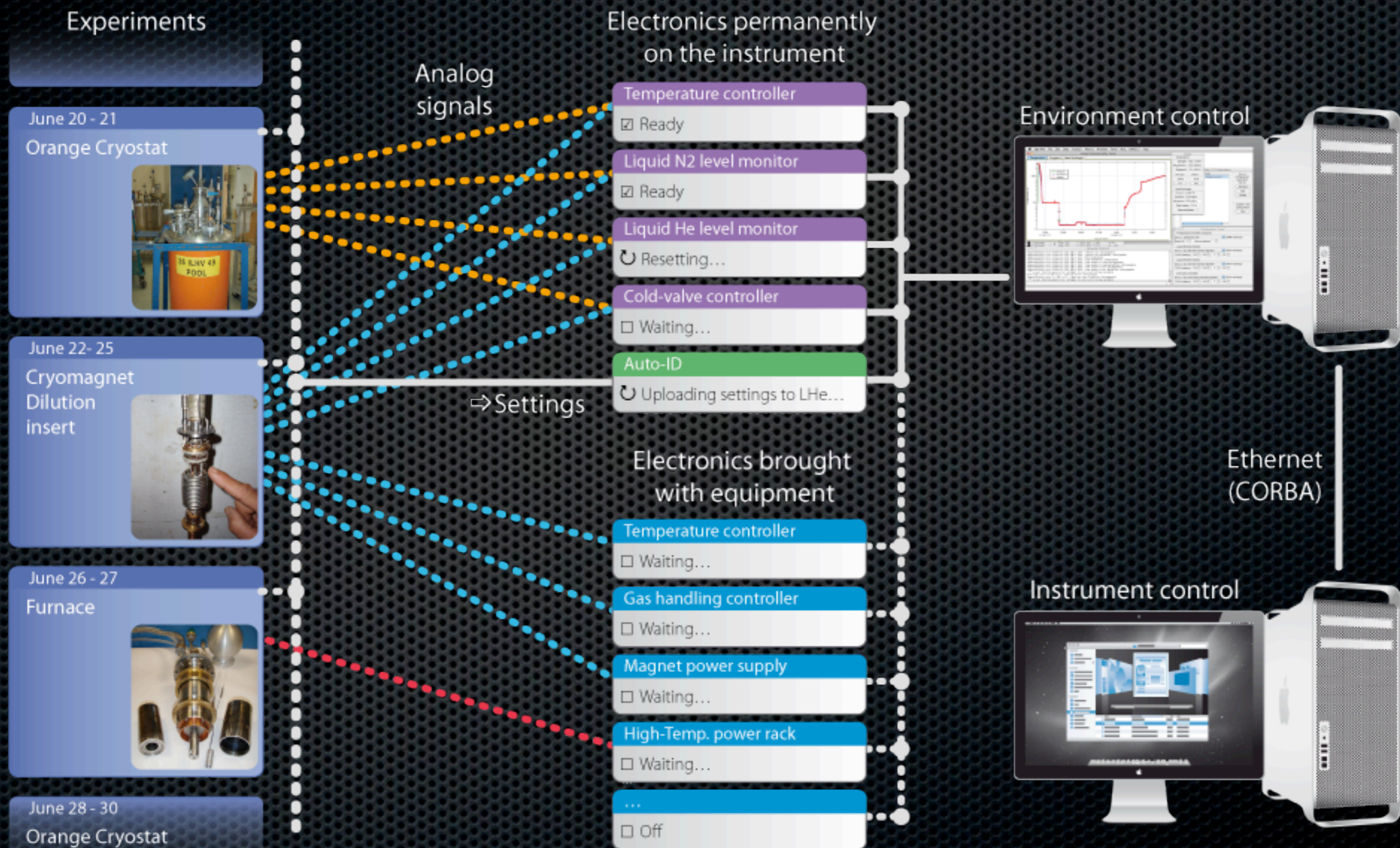

Temperature Cryogenics Heat Exchanger

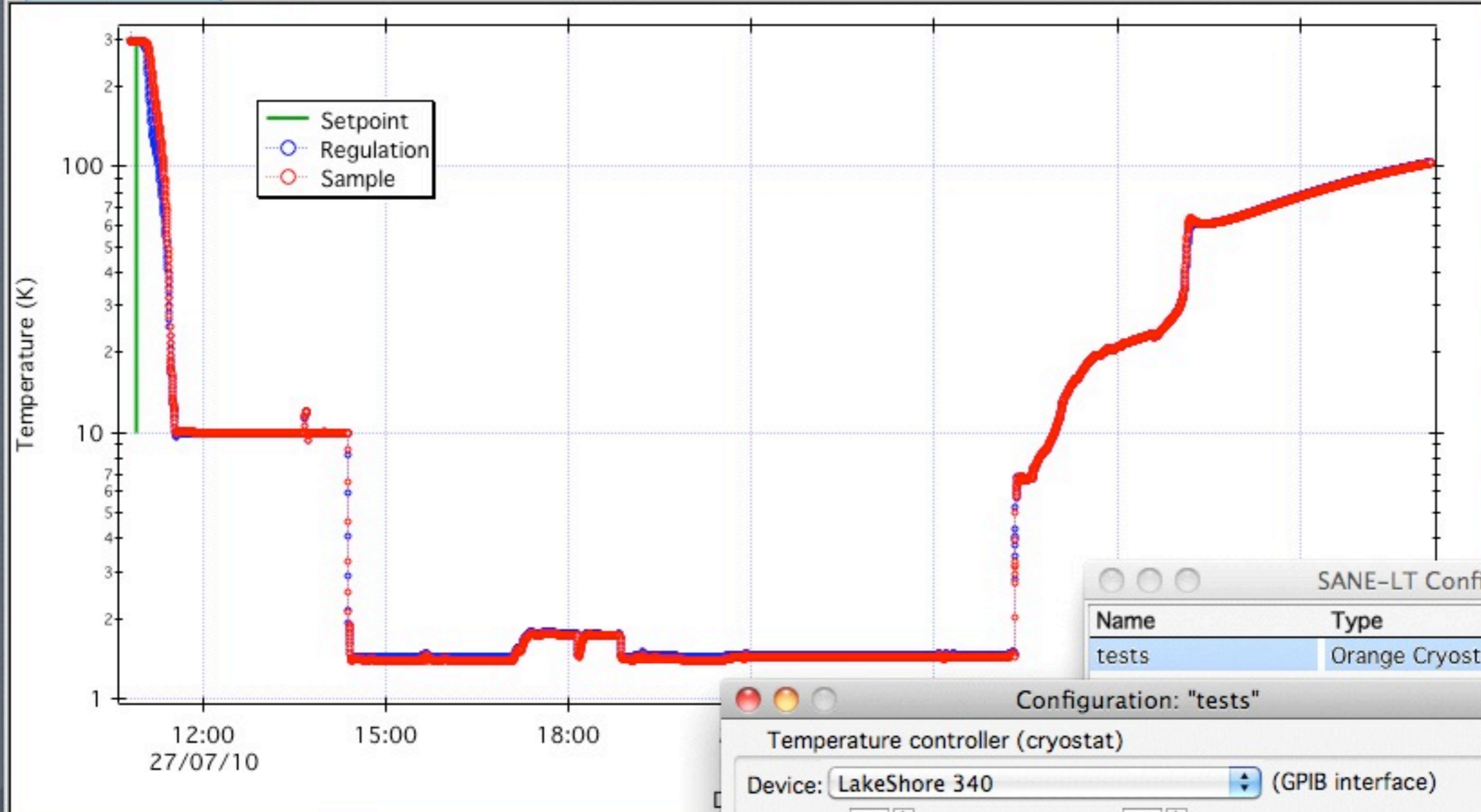

Control

Temperature

Sample: 103.116 K
 Regulation: 103.590 K
 Setpoint: 10.000 K

Nitrogen: 54 %
 Helium: 0 %

Fill (Nitrogen) Fill (Helium)

Heat Exchanger

Heater: 0.00 %
 Coolant: -0.40 mbar
 Setpoint: 10.00 mbar
 Cold-valve: 403 %
 Manual Mode:

SANE-LT Configurations

Name	Type
tests	Orange Cryostat

Configuration: "tests"

Temperature controller (cryostat)

Device: LakeShore 340 (GPIB interface)
 Board ID: 0 Device address: 2

Liquid N2 level monitor

Device: ILL LN2 level monitor (E3504) (IPv4 interface)
 TCP/IP address: 192 : 168 : 1 : 201

Liquid He level monitor

Device: ILL LHe level monitor (E3504) (IPv4 interface)
 TCP/IP address: 192 : 168 : 1 : 202

Cold-valve controller

Device: ILL Cold-valve controller (E3504) (IPv4 interface)
 TCP/IP address: 192 : 168 : 1 : 203

From a configuration selected in the list:

Activate
 Edit
 Delete

Create a new configuration:

New

```

•Edit/K=0 root:'E3504 CV (192.168.1.203)':Mode;DelayUpda
•AppendToTable root:'E3504 CV (192.168.1.203)':Mode Dat
•AppendToTable root:'E3504 CV (192.168.1.203)':Power;Del
•AppendToTable root:'E3504 CV (192.168.1.203)':Power Da
•AppendToTable root:'E3504 CV (192.168.1.203)':Pressure;
•AppendToTable root:'E3504 CV (192.168.1.203)':Pressure
•AppendToTable root:'E3504 CV (192.168.1.203)':SetPoint;
•AppendToTable root:'E3504 CV (192.168.1.203)':SetPoint
•AppendToTable root:'E3504 CV (192.168.1.203)':SetPoint
•AppendToTable root:'E3504 CV (192.168.1.203)':SetPoint
[Jeu 19 août 2010 @ 16:44:28]=> WARNING: Cannot open co
[Jeu 19 août 2010 @ 16:44:34]=> WARNING: Cannot open co
    
```

1.203".
 1.203".

Temperature **Cryogenics** Heat Exchanger

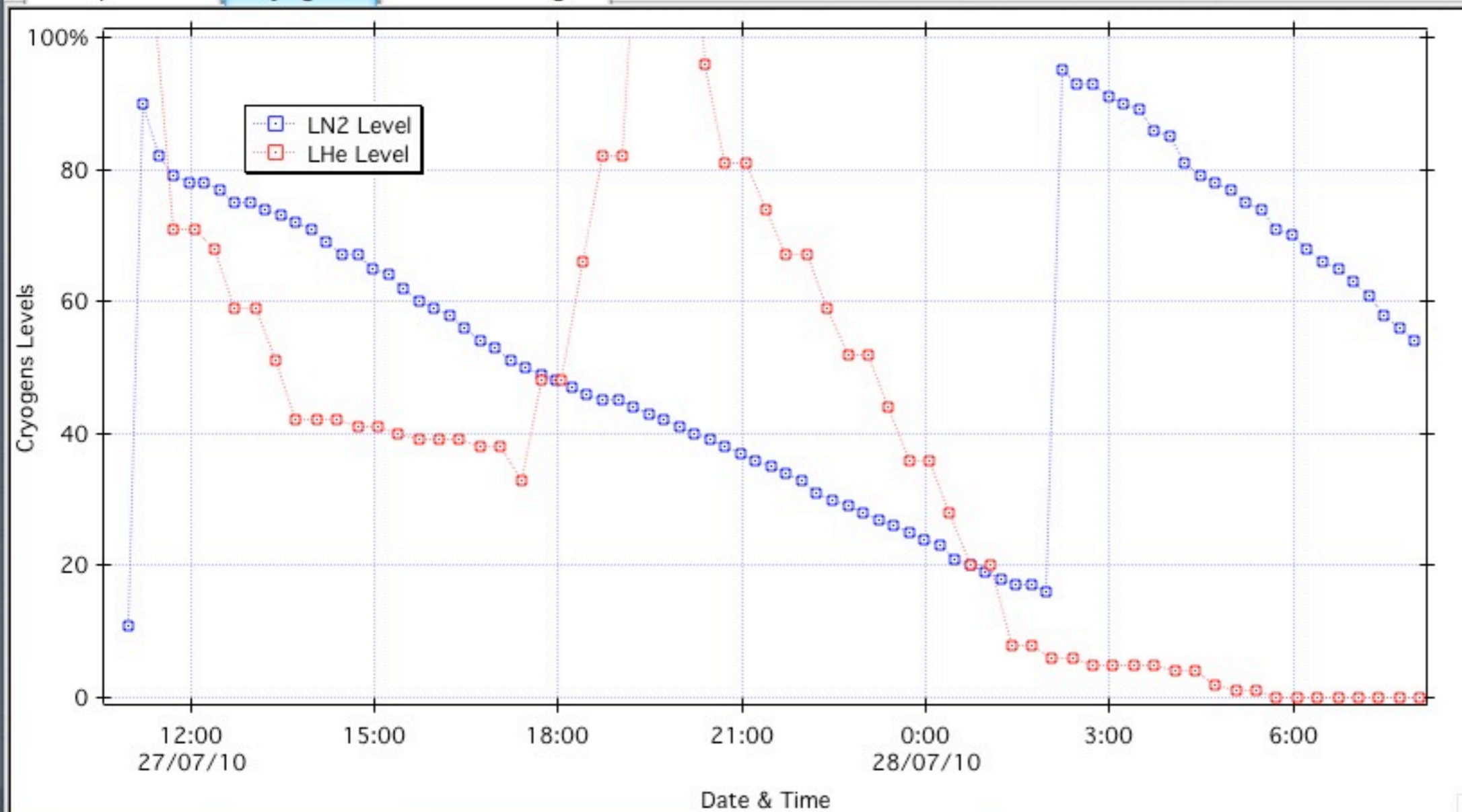

Control

Temperature
 Sample: 103.116 K
 Regulation: 103.590 K
 Setpoint: 10.000 K

Nitrogen: 54 % Fill
 Helium: 0 % Fill

Heat Exchanger
 Heater: 0.00 %
 Coolant: -0.40 mbar
 Setpoint: 10.00 mbar
 Cold-valve: 403 %
 Manual Mode:

Configurations

From a configuration selected in the list:

Activate
Edit
Delete

Create a new configuration:
New

```

•Edit/K=0 root:'E3504 CV (192.168.1.203)':Mode;DelayUpda
•AppendToTable root:'E3504 CV (192.168.1.203)':Mode Dat
•AppendToTable root:'E3504 CV (192.168.1.203)':Power;Del
•AppendToTable root:'E3504 CV (192.168.1.203)':Power Da
•AppendToTable root:'E3504 CV (192.168.1.203)':Pressure;
•AppendToTable root:'E3504 CV (192.168.1.203)':Pressure
•AppendToTable root:'E3504 CV (192.168.1.203)':SetPoint;
•AppendToTable root:'E3504 CV (192.168.1.203)':SetPoint
•AppendToTable root:'E3504 CV (192.168.1.203)':SetPoint
•AppendToTable root:'E3504 CV (192.168.1.203)':SetPoint
[Jeu 19 août 2010 @ 16:44:28]=> WARNING: Cannot open co
[Jeu 19 août 2010 @ 16:44:34]=> WARNING: Cannot open co
    
```

Board ID: 0 Device address: 2

Liquid N2 level monitor
 Device: ILL LN2 level monitor (E3504) (IPv4 interface)
 TCP/IP address: 192 : 168 : 1 : 201

Liquid He level monitor
 Device: ILL LHe level monitor (E3504) (IPv4 interface)
 TCP/IP address: 192 : 168 : 1 : 202

Cold-valve controller
 Device: ILL Cold-valve controller (E3504) (IPv4 interface)
 TCP/IP address: 192 : 168 : 1 : 203

1.203".
 1.203".

Temperature Cryogenics Heat Exchanger

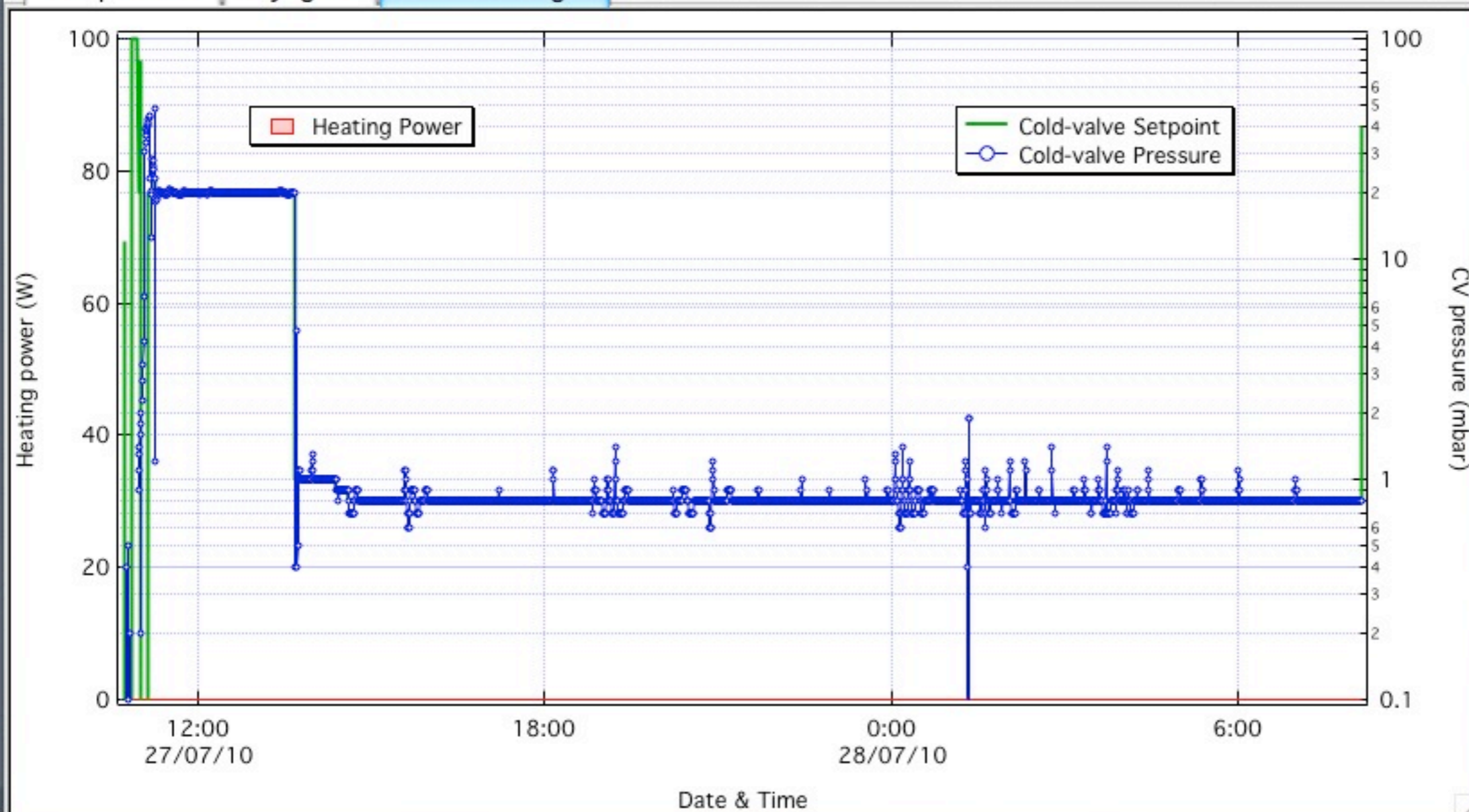

Control

Temperature

Sample: 103.116 K
 Regulation: 103.590 K
 Setpoint: 10.000 K

Nitrogen: 54 %
 Helium: 0 %

Fill Nitrogen Fill Helium

Heat Exchanger

Heater: 0.00 %
 Coolant: -0.40 mbar
 Setpoint: 10.00 mbar
 Cold-valve: 403 %
 Manual Mode:

81ilhv16-27/07/10

```

•Edit/K=0 root:'E3504 CV (192.168.1.203)':Mode;DelayUpdate
•AppendToTable root:'E3504 CV (192.168.1.203)':Mode Date&Time';DelayUpdate
•AppendToTable root:'E3504 CV (192.168.1.203)':Power;DelayUpdate
•AppendToTable root:'E3504 CV (192.168.1.203)':Power Date&Time';DelayUpdate
•AppendToTable root:'E3504 CV (192.168.1.203)':Pressure;DelayUpdate
•AppendToTable root:'E3504 CV (192.168.1.203)':Pressure Date&Time';DelayUpdate
•AppendToTable root:'E3504 CV (192.168.1.203)':SetPoint;DelayUpdate
•AppendToTable root:'E3504 CV (192.168.1.203)':SetPoint Date&Time';DelayUpdate
•AppendToTable root:'E3504 CV (192.168.1.203)':SetPoint Read';DelayUpdate
•AppendToTable root:'E3504 CV (192.168.1.203)':SetPoint Read Date&Time';DelayUpdate
[Jeu 19 août 2010 @ 16:44:28]=> WARNING: Cannot open connection with cold-valve Eurotherm controller at address "192.168.1.203".
[Jeu 19 août 2010 @ 16:44:34]=> WARNING: Cannot open connection with cold-valve Eurotherm controller at address "192.168.1.203".
    
```

Other perspectives

- UV/IR/Vi7s light scattering, new humidity chamber, new stopped flow, new rheometer, acoustic levitator,
- High-pressure H₂ systems, 4 GPa non-magnetic clamps,
- Sample changers for diffraction, SANS, etc.
- Cryomagnets for IN5, D33, XtremeD, TAS; Cryocradle,
- 40 mK to 320K fully automatic dilution refrigerators,
- Focusing optics in equipment, reduce background,
- Density meas. of liquid systems in furnace, etc.

Collaborations...

- ✦ Non-magnetic clamps: NMI3 contract - LLB, HZB, ISIS
- ✦ High-pressure H₂ systems: NMI3 contract - HZB, ISIS
- ✦ Levitation: ANR contract - CEMHTI, SIMAP, Soleil
- ✦ Pulsed magnet: ANR contract - CEA, CNRS, LNCMI
- ✦ Light radiation in HP cells: ANR contract - CNRS, Univ.
- ✦ Soft matter: NMI3 contract - JCNS, HZB, ISIS, LLB, FRM
- ✦ ³He-⁴He distiller for D10: collaboration with CRTBT
- ✦ Cryopad-EDM: PNPI, Cryopad-ToF: IUCL,...

Sample environment & Polarimetry

- S. Baudoin
- N. Belkhier
- E. Bourgeat-Lami
- J. Gonthier
- J.-P. Gonzales
- P. Courtois
- Y. Gibert
- J.-L. Laborier
- O. Losserland
- F. Marchal
- P. Martin
- J. Memphis
- D. Jullien
- P. Mouveau
- P. Mendes
- C. Payre
- X. Tonon
- S. Turc
- A. Petoukhov

**Many Thanks
for Your Feedback**

and many other colleagues & friends...